

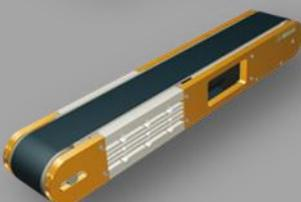

Operating Instructions Conveyor Systems

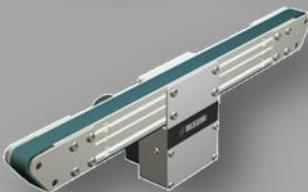
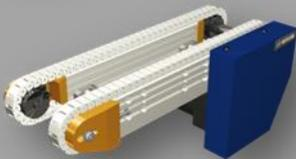

Carefully read the operating instructions before the first commissioning.

Observe safety instructions!

Keep in a safe place for future reference! The information contained in this document is subject to change without notice!

This is a translation of the original operating instruction.

MISUMI Europe GmbH

ENGLISH – February 2022



This manual is part of the technical documentation of the machine in accordance with the EC Machinery Directive.

This operating manual complies with „Directive 2006/42/EC of the European Parliament and Council on the approximation of the laws, regulations and administrative provisions of the Member States relating to machinery" (Machinery Directive), Annex I, Para. 1.7.4 for complete machinery and Annex VI for partially completed machinery.

The EU Declaration of Conformity or the EU Declaration of Incorporation can be found in the appendix to this operating manual.

The operating manual is addressed to the plant manager who must pass it on to the personnel responsible for installation, connection, use, and maintenance of the machine.

The plant manager must ensure that the information contained in the operating manual and in the accompanying documents has been read and understood.

The operating manual must be stored in a place that is familiar and easily accessible to employees and must be consulted whenever an employee is unsure of how to proceed.

Legal Notice

The manufacturer assumes no responsibility for damage to people, animals, or objects, or to the machine itself arising from improper use or through disregard or insufficient consideration of the operating instructions contained in the operating manual or resulting from alteration of the machine or the use of unsuitable replacement parts.

The copyright for the operating manual is held solely by



or their legal successor.

Reproduction or circulation of the operating manual may only be made with the express written permission of the copyright holder. This also applies when only excerpts of the operating manual are copied or circulated. The same conditions apply to circulation of the operating manual in digital form.

Version: February 2022

Pictograms & Signal Words

The following pictograms and signal words are used in this document. The combination of a pictogram and a signal word classifies the respective safety information. The pictogram may vary according to the type of danger depicted.

	Symbol	Signal Word	Explanation
Death		Danger	This signal word must be used when death or irreversible health injuries can occur due to non-compliance with the hazard information.
Injury Property Damage		Warning	This signal word indicates damage to persons and objects including injury, accident, and health risks.
		Caution	This signal word indicates danger of damage to objects. In addition, there is a slight risk of injury.
No Damage		Attention	This signal word may only be used if no damage to health can occur. It warns of malfunctions and is without a symbol, since the degree of danger is slight.
		Important	This signal word indicates cross-references and ways in which operation is facilitated. It excludes all danger of damage to objects and risks of injury, and thus is without a warning symbol.

Target Group

The operating manual is addressed to personnel within the following areas of responsibility:

Area of responsibility	Expertise
Transport	Specialised staff
Assembly / Installation / Disassembly / Commissioning	Specialised staff
Operating / Decommissioning	Trained personnel
Maintenance	Specialised staff
Maintenance and Repairs	Specialised staff
Troubleshooting	Specialised staff

Definition according to DIN EN 60204-1:

Trained personnel:

A person who has been instructed by an expert in the responsibilities he or she has been assigned and any possible hazards in case of improper behaviour, and who was trained in the use of the necessary protective devices and protective measures.

Specialised staff:

Persons who can evaluate the work assigned to them and recognise possible dangers on the basis of their specialised training, knowledge, experience, and familiarity with the relevant norms.

Archiving

- The operating manual as part of the technical documentation shall be retained as a document of record by the manufacturer for at least 10 years.
- The instructions must always be readily available!

Applicability of the EU Declaration of Conformity / Incorporation

This operating manual applies to the conveyor systems in the specified configuration options as described in Chapter 1, from page 2 on.

MISUMI Europa GmbH Conveyor Systems are generally delivered ready for installation, with CE marking and EU Declaration of Conformity. Upon individual customer request, MISUMI Europa GmbH can also supply conveyor systems without drives and/or conveyor belts!

Therefore, both an EU Declaration of Conformity for complete machinery and an EU Declaration of Incorporation for partially complete machinery are provided in the Appendix, Chapter 11 of this operating manual.

Applicability of the EU Declaration of Conformity

The EU Declaration of Conformity applies to complete conveyor systems (with drive and conveyor belt) and to conveyor systems without belts taking into consideration the requirements in Chapters 4.4 and 8.2. The conveyor systems bear the CE marking.

Applicability of the EU Declaration of Incorporation

The EU Declaration of Incorporation applies to conveyor systems without drive. These conveyor systems do not bear the CE marking.

1. Identification	2	4.3.23	CVSEE	23
1.1 MISUMI Article Number System	2	4.3.24	CVSFE	23
1.2 Intended Use	3	4.3.25	CVSXE	24
1.3 Improper Use	3	4.3.26	CVSYE	24
2. General Information.....	4	4.3.27	CVSFAE	25
2.1 Guarantee and Liability	4	4.3.28	CVSFBE	25
2.2 Objectives of the Operating Manual	4	4.3.29	CVSFCE	26
2.3 Signs and Symbols	4	4.3.30	CVSFDE	26
2.3.1 Mandatory Safety Signs	4	4.3.31	CVSJAE	27
2.3.2 Hazard Signs	4	4.3.32	CVSMAE	27
2.3.3 Prohibition Safety Signs	4	4.3.33	CVLP AE	28
2.3.4 Instruction Signs	4	4.3.34	CVMAE	28
3. Safety Instructions	5	4.3.35	CVMBE	29
3.1 Scope	5	4.3.36	CVSTCE	29
3.1.1 Obligations	5	4.3.37	CVSTRE	30
3.1.2 Responsibilities of the operating company	5	4.3.38	CVGTAE	30
3.1.3 Responsibilities of Operating Personnel	6	4.3.39	CVGTBE	31
3.2 Hazards / Residual Risks	6	4.3.40	CVGTNE	31
3.2.1 Hazards - Emissions	7	4.3.41	CVGTPE	32
3.2.2 Hazards - Mechanical Energy	7	4.3.42	CVSPA E	32
3.3 Emergency Situations	8	4.3.43	CVSSAE	33
4. Installation and Operation.....	9	4.3.44	CVDSAE	33
4.1 Technical Data	9	4.3.45	CVDSBE	34
4.2 Conveyor System Types	9	4.3.46	CVSPCE	34
4.2.1 Drive Motor Installation Options	9	4.4	Belts Overview	35
4.2.2 Belt Conveyor	9	4.4.1	Technical Data - Belt	35
4.2.3 Chain Conveyor	10	4.4.2	Exchanging the Belts/Plastic Chains	38
4.2.4 Timing belt conveyor	10	4.5	Components – Electrical system/Control	41
4.3 Conveyor System Configurations	10	4.5.1	Drive motor	41
4.3.1 SVKAE	12	4.5.2	Electric Speed Controller	41
4.3.2 SVKBE	12	4.6	Safety Coverings	42
4.3.3 SVKNE	13	4.7	Frequently Asked Questions (FAQ)	42
4.3.4 SVKRE	13	5. Transportation, Installation, Connection	43	
4.3.5 GVHAE	14	5.1	Transport	43
4.3.6 GVFAE	14	5.2	Installation	43
4.3.7 GVHNE	15	5.2.1	Unpacking and Installation	43
4.3.8 GVFNE	15	5.2.2	Alignment of the Conveyor System	44
4.3.9 GV TSAE	16	5.3	Operating conditions	44
4.3.10 GV TSNE	16	5.4	Connection	44
4.3.11 GVTWAUE	17	5.4.1	Connection Location of the Machine	45
4.3.12 GVTWASE	17	5.5	Wiring Diagram	47
4.3.13 GVTWNUE	18	5.5.1	Motor Manufacturer A (Panasonic Motor)	47
4.3.14 GVTWNSE	18	5.5.2	Motor Manufacturer B (Oriental Motor)	48
4.3.15 CVGAE	19	5.6	Connection of Third-Party Drives	49
4.3.16 CVGCE	19	5.6.1	Maximum Permissible Torque	49
4.3.17 CVGNE	20	5.6.2	Maximum permissible conveying speed	49
4.3.18 CVGRE	20	5.6.3	Drive Motor Dimensions	49
4.3.19 CVGBE	21	5.6.4	Drive Motor Adapter Plates	51
4.3.20 CVGDE	21	6. Operation	52	
4.3.21 CVGPE	22	6.1	Commissioning	52
4.3.22 CVGWE	22	6.2	Checking functionality prior to operation	52
		6.3	Switching on the conveyor system	52
		7. Shut-down.....	53	

7.1	Switching off the conveyor system	53
7.2	Bringing the machine to a standstill	53
7.3	Relocation of the machine	53
7.4	Disposal of the machine	54
8.	Set-up and Accessories	55
8.1	Drive change	55
8.2	Belt change	55
8.2.1	Belt change - Head drive	56
8.2.2	Belt change - Central drive	57
8.2.3	Belt Change - Integrated Drive	58
8.3	Alignment Correction	58
8.3.1	Alignment Correction Direct Drive Conveyors	58
8.3.2	Alignment Correction Centre Drive Conveyors	59
8.3.3	Alignment correction - Integrated Drive	59
8.4	Tensioning Belt	59
8.5	Recommissioning	59
8.6	Accessories	60
8.6.1	Support stand	60
8.6.2	Mounting brackets (supports)	60
8.6.3	Metal guide rails	60
8.6.4	Plastic guide rails	60
8.6.5	Guide rail brackets	61
8.6.6	Transfer rollers	61

8.6.7	Plastic covers	61
8.7	Spare parts	61
8.8	Order	61
9.	Maintenance.....	62
9.1	Cleaning of the conveyor system	63
9.2	Packing of machine parts	63
9.3	Maintenance information	63
9.4	Finishing maintenance work	64
10.	Fault Clearance.....	65
10.1	Procedure in Case of Operational Malfunctions	65
10.2	Troubleshooting	65
10.3	Frequently Asked Questions (FAQ)	66
EC Conformity Declaration.....		67
EU Declaration of Incorporation.....		68

1. Identification

Designation	Conveyor systems* <ul style="list-style-type: none"> ■ Conveyor system (complete) ■ Conveyor system without drive ■ Conveyor system without belt ■ Conveyor system without drive/ without belt
Model year	2022
Service life	<ul style="list-style-type: none"> ■ 10,000 hours. Typically 5 years (8 h/day, 5 Days/week at constant load) under normal operating conditions ■ Increased load, dirt, wear or heat can impair these values!

Manufacturer	MISUMI Europa GmbH Franklinstraße 61–63 60486 Frankfurt am Main Germany
Email	Mail.tech@misumi-europe.com
Web	www.misumi-europe.com

* This operating manual is equally valid for multiple different conveyor system configurations! Any differences in the applicability will be pointed out, as necessary, at the beginning of the respective chapter!

1.1 MISUMI Article Number System

MISUMI article numbers contain the basic technical parameters and characteristic values of the conveyor system in coded form.

XXXX—**100**—**1000**—**25**—**TA230**—**IM**—**25**—**H**—**C**

XXXX	Type designation of the conveyor
100	Width in mm
1000	Length in mm
25	Motor power output in watts
TA230	Operating voltage indicator in V
IM/SCM	Control variant indicator
25	Transmission ratio indicator
H	Belt specification indicator
C	Motor manufacturer indicator

The article numbers differ according to the configuration of the conveyor system. The code logic is described below using an example.

Conveyor system (complete)

SVKAE-100-500-25-TA230-SCM-12.5-H-B

SVKAE	Type designation of the conveyor
100	Width in mm
500	Length in mm
25	Motor power output in watts
TA230 (230V/50 Hz)	Operating voltage V
SCM (control motor)	Control variant
12,5	Gear transmission ratio
H	Belt specification
B (Oriental motor)	Motor manufacturer

Conveyor system without drive

SVKAE-100-500-25-[NV]-[NM]-[NH]-H-[R]*

SVKAE	Type designation of the conveyor
100	Width in mm
500	Length in mm
25	Motor power output in watts
-	Operating voltage V
-	Control variant
-	Gear transmission ratio
H	Belt specification
-	Motor manufacturer

* Without motor, without gear head, without feather keys

Conveyor system without belt

SVKAE-100-500-25-TA230-SCM-12.5-[J]-B

SVKAE	Type designation of the conveyor
100	Width in mm
500	Length in mm
25	Motor power output in watts
TA230 (230V/50 Hz)	Operating voltage V
SCM (control motor)	Control variant
12,5	Gear transmission ratio
-	Belt specification
B (Oriental motor)	Motor manufacturer

Conveyor system without drive/without belt

SVKAE-100-500-25-[NV]-[NM]-[NH]-[J]-[R]

SVKAE	Type designation of the conveyor
100	Width in mm
500	Length in mm
25	Motor power output in watts
-	Operating voltage V
-	Control variant
-	Gear transmission ratio
-	Belt specification
-	Motor manufacturer

1.2 Intended Use

The conveyor systems are for linear transport of solid materials in a defined direction of conveyance, which corresponds to the specific conveying capacity and material properties of the belt. The material is deposited on the conveyor system and transported over the entire length of the belt.

For conveyor systems that are delivered without conveyor belts, proper use also means that these must never be put into operation first installing the conveyor belt. The belt must be either an original MISUMI accessory, or a conveyor belt, whose technical specifications match those of original MISUMI conveyor belts (refer to Chapter 4.4, from page 35 on).

For conveyor systems that are delivered without drive motor, proper use also means that the drive motors provided by the User must meet the technical specifications stipulated in Chapter 4.5.1, from page 41 on.

The conveyor systems are intended for use in a non-explosive atmosphere.

A different or additional use of the machine is considered as non-designated use and thus improper. In this case, the safety mechanisms and the protection provided by them may be compromised. MISUMI Europa GmbH is not liable for damages resulting from such use.

Compliant use also includes the following:

- following all instructions in the operating manual,
- following all safety instructions,
- compliance with rules pertaining to inspection and maintenance work.

1.3 Improper Use

For all operating modes, improper use, which can endanger the machine, the user and others, includes:

- the use of the conveyor system and its electronic equipment in contradiction with its intended use (1.1),
- the conveyance of non-approved materials such as sand, gravel and other granular materials goods and/or workpiece holders, whose shape and dimensions differ from the shape and dimensions they were designed for,
- transport of people or animals,
- the operation of conveyor systems in reverse direction,
- the operation of conveyor systems outside of the physical limitations of use defined in chapter "Operating conditions" page 44,
- modifying the control software without first consulting MISUMI Europa GmbH,
- modifying, extending or reconstructing the conveyor systems without first consulting MISUMI Europa GmbH,

- operating the conveyor system contrary to the specifications provided in the operating manual with respect to safety, installation, operation, maintenance and repair, set-up and malfunctions,
- bridging or decommissioning of safety and protective devices of the system,
- operating the machine when there are obvious malfunctions,
- repair, cleaning, and maintenance work without disconnecting the system from power.

WARNING



Risk of unauthorised modifications

Carrying out unauthorised modifications to the machine and the use of replacement parts from other manufacturers constitutes a danger.

Only use original replacement, and wear and tear parts from the manufacturer.

Do not modify, extend, or reconstruct the machine without consent of MISUMI Europa GmbH. This also applies to the welding of structural components

WARNING



Risks due to improper use

There are risks (malfunction, injury) related to improper use of the machine.

Use the machine exclusively according to its intended use.

2. General Information

2.1 Guarantee and Liability

The “General Sales and Delivery Conditions” of MISUMI Europa GmbH apply. These are available to the operating company at signing of the contract, at the latest.

Liability and warranty claims in cases of injury to persons or damage to property are excluded if they can be attributed to one or more of the following causes:

- improper use of the conveyor systems,
- improper assembly, commissioning, operation and maintenance of the conveyor systems,
- operation of the machine with defective safety equipment,
- disregarding the information in the operating manual,
- unauthorised structural modification of the machine,
- inadequate maintenance, repair and servicing measures,
- disasters due to the effects of foreign objects or force majeure.

2.2 Objectives of the Operating Manual

These operating instructions serve as supporting documentation and contain all necessary safety information that must be followed for general safety, transport, installation, operation, maintenance, and set-up.

These operating instructions with all safety information (as well as all additional documents of the components from external suppliers) must be:

- observed, read and understood by all persons working on the machine (especially the safety information),
- easily available at all times to all persons,
- immediately consulted in case of the slightest doubt (safety).

2.3 Signs and Symbols

DANGER	
	Risks due to failure to observe safety signs
	Risks exist when ignoring the warnings and signs on the machine and in the operating manual.
	Respect warnings and signs!

The following special safety signs in accordance with DIN 4844-2 are used in the corresponding passages in the text of these operating instructions and on hazardous points on the machine, and require special attention depending on the combination of signal word and symbol:

2.3.1 Mandatory Safety Signs

	Protective clothing!		Unplug!
	Headgear use!		Hand protection!
	Use safety shoes!		Wear goggles!
	Secure state!		Release before operation!
	Pay attention to additional information!		Pay attention to documentation!

2.3.2 Hazard Signs

	Hot surface		Dangerous electrical voltage
	Danger of falling		Danger of crushing
	Danger of tripping		Hand injuries
	Slip hazard		Automatic start-up
	Explosive atmosphere		Suspended load
	Harmful or irritating substances		Flammable materials
	Entanglement risk		Danger zone
	Harmful emissions		Tipping of loads

2.3.3 Prohibition Safety Signs

	Unauthorised access prohibited		Fire, open flame and smoking prohibited
	Storing or setting down prohibited		Do not enter
	Extinguishing with water prohibited		Do not step under raised loads

2.3.4 Instruction Signs

	Dangerous to the environment
--	------------------------------

3. Safety Instructions

3.1 Scope

DANGER



Risks due to failure to observe safety instructions

There are risks if the operating manual and the safety information contained therein are disregarded.

Carefully read the operating instructions before the first commissioning. Fulfil necessary safety conditions before initial commissioning!

Observe general safety instructions and the special safety instructions included in the other chapters!

Follow safety instructions on the machine!

The machine has been constructed according to state-of-the-art technology and recognised safety regulations. In order to exclude the possibility of danger to life and limb of the user, third parties, or damage to the machine during its operation, use the machine exclusively for its intended purpose and only if the machine is in an obviously safe and sound condition.

Bodily injuries and/or property damages resulting from non-compliance with the operating instructions are the responsibility of the company operating the machine or of the persons it designates. Malfunctions that could compromise safety must be eliminated immediately.

All safety instructions and warnings on the machine must be observed and are always to be kept in legible condition.

3.1.1 Obligations

DANGER



Risk due to negligent behaviour

Despite numerous protective and safety devices, there are always hazards associated with careless behaviour while operating the machine.

Always work on the machine with great care and caution. Disregarding safety information will lead to a loss of any rights to compensation for damage claims!

The following events may increase the hazard potential of the machine:

- Failure of important functions of the machine,
- Failure of prescribed methods for maintenance and upkeep,
- Endangerment of individuals through electrical or mechanical sources.

3.1.2 Responsibilities of the operating company

Safe operating conditions and use of the machine are a prerequisite for operating the machine without risks. The operating company therefore has a duty to make sure that the following are in compliance:

- Make sure that the machine is only operated by trained and authorised personnel. Observe the minimum age allowed by law!
- Forbid unsafe and/or dangerous work procedures. If necessary, monitor the actions of personnel!
- Personnel that is in training, under instruction, or in the course of general education on the machine, must be under the supervision of an experienced person at all times!
- Personnel must have understood the operating instructions. Have this confirmed by signature!
- Guarantee that a copy of the complete operating manual is on hand and always available in the area of the machine!
- Check the operating manual regularly to ensure that they are complete and legible!
- Mandate wearing protective gear for activities with an increased risk of injuries!
- Precisely define the duties (operation, maintenance) of each area of responsibility!
- Make it mandatory for the operating and maintenance personnel to immediately report any deficiencies in safety to their superiors as soon as they occur or are identified!

DANGER



Danger to life due to misconduct or lack of qualifications while operating the machine



There are dangers from misuse due to lack of qualification and general human error while operating the machine.

The operating company must mandate operation of the machine according to the operating manual!

Only allow skilled personnel to perform maintenance, cleaning and troubleshooting!

Only allow qualified electricians to perform work on the electrical supply system!

Staff working on the machine must periodically receive training and be made aware of the safety features!

WARNING



Risk of injury when belts are missing

There is a risk of injury if the conveyor belt is not installed as moving components of the conveyor system are accessible when the system is switched on.

When changing the belt or when a belt is not installed, the conveyor system must be safety disconnected from the power supply!

Never switch on the conveyor system without a belt, as the belt also acts as an isolating safety guard!

3.1.3 Responsibilities of Operating Personnel

Operating personnel are obligated to contribute to the prevention of work accidents and the consequences of them through their personal conduct.

WARNING



Insufficiently trained personnel pose a hazard to other persons and to proper operation.

The system may only be used by trained personnel. New operators must be trained by existing operators. The operating company must have the personnel's areas of responsibility, competence, and monitoring precisely regulated.

Personnel assigned to the areas of responsibility mentioned above must have the corresponding qualification for this work (training, instruction). If necessary, this can be done by the manufacturer on behalf of the operating company. In case of disregard, all warranty claims are void.

WARNING



Risk of injuries due to an improper condition of the machinery

Risks occur during operation due to breakdowns or malfunctions.

Check the condition of the safety equipment and the overall condition of the machine at least once per shift!

Do not switch the machine on, and secure it against accidental start!

3.2 Hazards / Residual Risks

Various risk situations can occur on the conveyor system energy being released due to malfunction or during normal operation.

Residual energy is still present in the cables and components of the equipment after it has been switched off.



Attention

Even if all precautions have been taken, there may be residual risks that are not apparent.

Residual risks can be reduced by following all safety instructions, respecting the intended use as well as heeding the operating instructions and operating manual.

In the interests of occupational health and safety, an operator's manual is required, which the operating company must issue!

Source of danger	Example
Electrical energy	Electronic components and freely accessible, current-conducting components
Mechanical energy	Drive shafts, belts and chains
Thermal energy	Hot motor surfaces
Residual energy	Mechanical and electrical residual energy after switching off the machine
Emissions	Airborne sound (noise)

DANGER



Danger of electric shock from faulty electrical components, contact with live parts, human error and lack of qualifications!



There are hazards from electric energy and residual energy. Live current remains in cables, components and equipment for about 5 minutes after the machine is turned off.



Live parts may be freely accessible in the switch box and at connection points of the electrical components!



Prior to operation, disconnect the conveyor system from the power supply and ensure that it is secured against accidental and unauthorised restart!

Only allow trained personnel to work on the electrical supply or accessible live components!

Non-compliance (e.g. freely accessible contacts, incorrect placement of the ground conductor, etc.) can lead to electric shock and, as a result, to serious injury or death!

WARNING

Danger of injury due to hot surfaces

There is a danger of injury due to contact with the outer casing of the motor during operation and after shut down.



Maintain safety distance and wear appropriate protective clothing.

3.2.1 Hazards - Emissions

The continuous noise level of the conveyor system is maximum <70 dB (A). Depending on local conditions, the noise level can be higher or lower.

Transporting the material to be conveyed and the belt composition can produce a higher noise level. The noise levels must be monitored by the operating company and appropriate protective measures taken. For these cases, noise mitigation measures can be requested from the manufacturer.

WARNING

Risk of injury due to noise

The continuous noise level from the machine may result in hearing loss.



Protect yourself from noise-induced hearing loss by wearing hearing protection!

There are no further emissions from the conveyor.

3.2.2 Hazards - Mechanical Energy
WARNING

Crushing and hand injuries

There is a risk of injury if a body part is caught between moving components, such as the supply chain or belt and stationary components.



During operation it is strictly forbidden to reach into or step into the operating area of the machine. Precautions against crushing and amputation risks must be taken when cleaning, setting up, maintaining and troubleshooting!

Only qualified personnel may work on the machine, and only when it is shut down!

Wear protective equipment!

WARNING

Risk due to entanglement with the conveyor system (projecting conveyed materials, moving workpiece holders, chains and belts)

There is danger anywhere in the system that body parts can be crushed when clothes, limbs, hair or tools are engaged or pulled into the machine. Especially in dangerous areas of the conveyor systems where energy is transferred or there is a change of direction.



Position conveyed materials on workpiece holders so that they are never a danger to staff or the machine!



Never operate machinery without safety equipment (mechanical and electronic). Only bridge or dismantle security equipment when it is absolutely necessary!

Make sure that no unauthorised persons obtain access to the machine during start-up!

Prohibit third-party access to the work and service area!

Wear tight-fitting protective clothing!

Wear protective equipment!

WARNING

Crushing Injuries due to backed-up conveyed materials

When removing the cause for a back-up, fingers and hands can be crushed between conveyed materials by the pressure that is released, or the conveyed materials can fall on the operator's feet.



In case of malfunction, the conveyor must be shut down immediately!

Remove jammed or wedged materials using tools (e.g. forceps). Never use bare hands!

Wear protective clothing!

WARNING

Danger of falling when transporting people

There are dangers when people stand on or allow themselves to be transported by the conveyors.

Never stand or ride on running or stationary conveyors!

Prohibit third parties from remaining near the equipment!

Secure access to the conveyor system!

3.3 Emergency Situations



Important

Take a first-aid course at regular intervals!

The operating instructions issued by the operating company in case of an emergency (fire, accident) must always be obeyed. The following recommendations are only general recommendations from standards institutions.

DANGER



Danger of death due to electric shock

Danger of death due to electric shock exists when fighting fires with water.



Never use water to extinguish fuel fires (oil, gasoline, solvents) or electrical fires!



Extinguish fires with CO₂!

If possible, turn off equipment before extinguishing fires!

4. Installation and Operation



Safety Instructions

Follow safety instructions in Chapter 3, "Safety Instructions".

In addition, all safety instructions and signs on the conveyor system and in the manufacturer's documentation in the appendix must be heeded.

4.1 Technical Data

Voltage rating	230 V
Tolerated voltage fluctuation	± 10 %
Frequency	50 Hz
Tolerated frequency fluctuation	1 %
Motor protection	6W / k A.; 15W/0.4A; 25W/0.6A; 40W/1.0A; 60W/1.4A; 90W/2.0A
Type of power connection	Fixed connection
Airborne sound	≥ 55 ≤ 70 dB
Electromagnetic compatibility	according to the EMC Directive and the applicable EMC standards for use in an industrial area
Explosive atmosphere	no
Conveyor speed	constant or variable



Technical data

Further information and detailed technical data on each conveyor system can be found in the following descriptions as well as the respective manufacturer's documentation of the motors. These are located in this manual!

4.2 Conveyor System Types

MISUMI offers three different conveyor systems, which differ greatly in construction depending on the customer's requirements and the material that is to be conveyed.

- Belt conveyor
- Chain conveyor
- Timing belt conveyor

The conveyor systems consist of the following, depending on the type (flat belts, timing belts, plastic chain conveyors):

- an individual frame,
- a drive motor, with or without speed regulator,
- idler pulley,
- conveyor belt.

Depending on the motor type, control of the motor is managed with motor circuit breakers or electronic controllers.

4.2.1 Drive Motor Installation Options

There are three ways of installing the drive at the conveyor system.

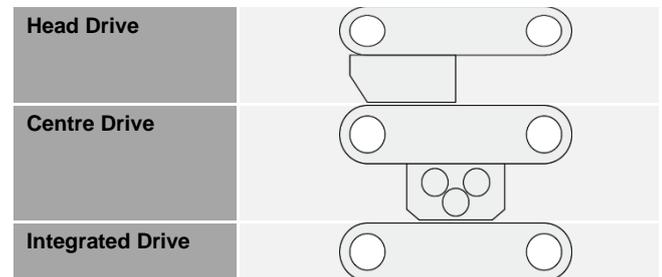

4.2.2 Belt Conveyor

Mechanical Structure

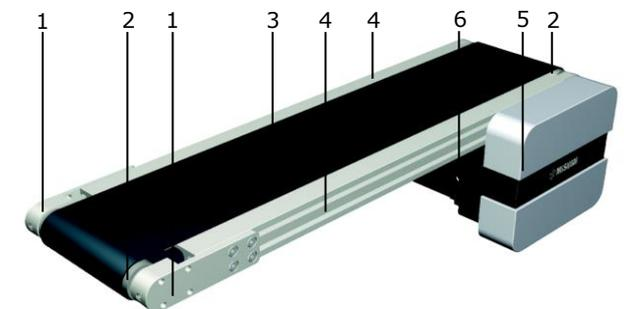

- | | |
|--------------------|---------------------------------|
| 1 Protective cover | 4 Frame |
| 2 Belt pulley | 5 Drive guard |
| 3 Conveyor belt | 6 Drive unit (here, head drive) |

Special Features

- Single track
- Low noise transport
- Transport of piece goods
- Supplements roller conveyors
- Easy to combine with other conveyor technologies
- Conveyor bed fully integrated in the frame
- Belt return in the frame
- Long conveyor models have support rollers in the lower run
- Modules are easy to combine with each other
- Low maintenance requirement
- Model with belt run protection wedge available
- Knife-edge models available

4.2.3 Chain Conveyor

Mechanical Structure

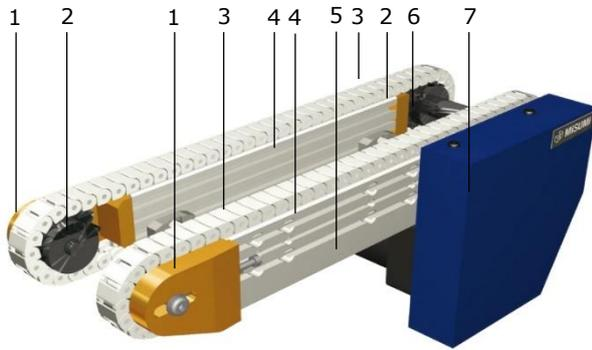

- | | | | |
|---|------------------|---|-------------------------------|
| 1 | Protective cover | 5 | Drive unit (here, head drive) |
| 2 | Sprocket | 6 | Drive shaft |
| 3 | Plastic chain | 7 | Drive guard |
| 4 | Frame | | |

Special Features

- Two-track
- Positive, slip-free drive
- Transport of heavy loads
- Chains are guided and can be re-tensioned
- Chain strands are driven by the motor via a drive shaft, thus ensuring synchronous running

4.2.4 Timing belt conveyor

Mechanical Structure

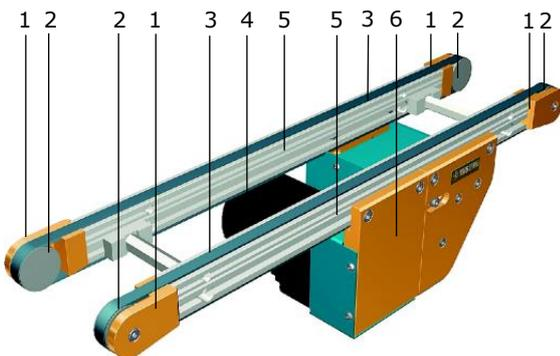

- | | | | |
|---|------------------|---|---------------------------------|
| 1 | Protective cover | 4 | Drive unit (here, center drive) |
| 2 | Belt pulley | 5 | Frame |
| 3 | Timing belt | 6 | Drive guard |

Special Features

- Two-track
- Positive, slip-free drive
- Transport of bulky goods
- Timing belts are guided and can be re-tensioned
- Timing belts are driven by the motor via a drive shaft, thus ensuring synchronous running

4.3 Conveyor System Configurations

MISUMI conveyor systems are configured differently based on planning and order placement.

- Conveyor system with drive and belt
- Conveyor system without drive
- Conveyor system without belt
- Conveyor system without drive and without belt



Note

Heed the differing applicability of this operating manual for the various conveyor system configuration and the specific safety instructions for conveyor systems supplied without conveyor belt and/or drive unit!



Accessories

A range of different accessories is available for the conveyor systems described below. Refer to the chapter "Accessories" on Page 60 for more detailed information.

Page	Designation	Type
12	SVKAE	Flat belt conveyor
12	SVKBE	Flat belt conveyor
13	SVKNE	Flat belt conveyor
13	SVKRE	Flat belt conveyor
14	GVHAE	Flat belt conveyor
14	GVFAE	Flat belt conveyor
15	GVHNE	Flat belt conveyor
15	GVFNE	Flat belt conveyor
16	GV TSAE	Timing belt conveyors
16	GV TSNE	Timing belt conveyors
17	GVTWAE	Timing belt conveyors
17	GVTWASE	Timing belt conveyors
18	GVTWNUE	Timing belt conveyors
18	GVTWNSE	Timing belt conveyors
19	CVGAE	Flat belt conveyor
19	CVGCE	Flat belt conveyor
20	CVGNE	Flat belt conveyor
20	CVGRE	Flat belt conveyor
21	CVGBE	Flat belt conveyor
21	CVGDE	Flat belt conveyor
22	CVGPE	Flat belt conveyor
22	CVGWE	Flat belt conveyor
23	CVSEE	Flat belt conveyor
23	CVSFE	Flat belt conveyor
24	CVSXE	Flat belt conveyor
24	CVSYE	Flat belt conveyor
25	CVSFAE	Full belt conveyor
25	CVSFBE	Full belt conveyor
26	CVSFCE	Full belt conveyor
26	CVSFDE	Full belt conveyor
27	CVSJAE	Flat belt conveyor
27	CVSMAE	Flat belt conveyor
28	CVLP AE	Flat belt conveyor
28	CVMAE	Flat belt conveyor
29	CVMBE	Flat belt conveyor
29	CVSTCE	Timing belt conveyors
30	CVSTRE	Timing belt conveyors
30	CVGTAE	Timing belt conveyors
31	CVGTBE	Timing belt conveyors
31	CVGTNE	Timing belt conveyors
32	CVGTPE	Timing belt conveyors
32	CVSPA E	Plastic chain conveyors
33	CVSSAE	Stainless steel conveyor belt
33	CVDSA E	Flat belt conveyor with studs
34	CVDSBE	Flat belt conveyor with studs
34	CVSPCE	Plastic chain conveyors

4.3.1 SVKAE

Special features

- Flat belt conveyors, single belt
- Pulley Ø 30 mm
- Head drive

Technical data

Belt Width (mm) *	50~400	
Length (mm)*	300~3000	
Weight (kg)*	3.7~28.8	
Power output (W)*	6	25
Voltage (V)	230	
Frequency (Hz)	50	

* Specifications depend on the design of the conveyor

Conveyor Capacity

Permissible transfer mass (vertically in kg) as a function of belt speed (horizontal in m / min) and selected transmission ratio

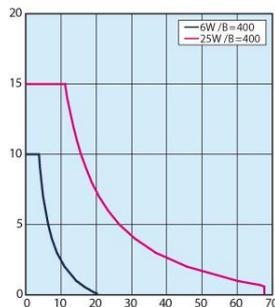
Gearhead reduction ratio

Belt speed (m / min) as a function of the frequency and the selected gearhead reduction ratio

	Belt speed	
	50 Hz	60 Hz
5	56.4	67.7
7.5	37.6	45.1
9	31.3	37.6
12.5	22.6	27.1
15	18.8	22.6
18	15.7	18.8
25	11.3	13.5
30	9.4	11.3
36	7.8	9.4
50	5.6	6.8
60	4.7	5.6
75	3.8	4.5
90	3.1	3.8
100	2.8	3.4
120	2.4	2.8
150	1.9	2.3
180	1.6	1.9

Further information

- Connection ▶ from page 43
- Belt characteristics ▶ from page 36
- Accessories ▶ from page 63

4.3.2 SVKBE

Special features

- Flat belt conveyors, single belt
- Pulley Ø 30 mm
- Head drive
- Belt with meandering prevention crosspiece

Technical data

Belt Width (mm) *	50~400	
Length (mm)*	300~3000	
Weight (kg)*	3.7~28.8	
Power output (W)*	6	25
Voltage (V)	230	
Frequency (Hz)	50	

* Specifications depend on the design of the conveyor

Conveyor Capacity

Permissible transfer mass (vertically in kg) as a function of belt speed (horizontal in m / min) and selected transmission ratio

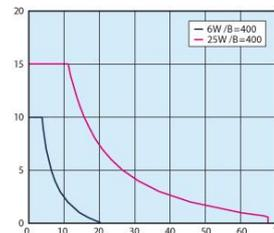
Gearhead reduction ratio

Belt speed (m / min) as a function of the frequency and the selected gearhead reduction ratio

	Belt speed	
	50 Hz	60 Hz
5	56.4	67.7
7.5	37.6	45.1
9	31.3	37.6
12.5	22.6	27.1
15	18.8	22.6
18	15.7	18.8
25	11.3	13.5
30	9.4	11.3
36	7.8	9.4
50	5.6	6.8
60	4.7	5.6
75	3.8	4.5
90	3.1	3.8
100	2.8	3.4
120	2.4	2.8
150	1.9	2.3
180	1.6	1.9

Further information

- Connection ▶ from page 43
- Belt characteristics ▶ from page 36
- Accessories ▶ from page 63

4.3.3 SVKNE

Special features

- Flat belt conveyors, single belt
- Pulley Ø 30 mm
- Central drive

Technical data

Belt Width (mm) *	50~400				
Length (mm)*	390~3000				
Weight (kg)*	5.4~41.5				
Power output (W)*	6	25	40	60	90
Voltage (V)	230				
Frequency (Hz)	50				

* Specifications depend on the design of the conveyor

Conveyor Capacity

Permissible transfer mass (vertically in kg) as a function of belt speed (horizontal in m / min) and selected transmission ratio

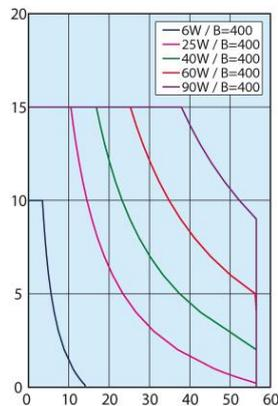

Gearhead reduction ratio

Belt speed (m / min) as a function of the frequency and the selected gearhead reduction ratio

	Belt speed	
	50 Hz	60 Hz
5	47.1	56.5
7.5	31.4	37.7
9	26.2	31.4
12.5	18.8	22.6
15	15.7	18.8
18	13.1	15.7
25	9.4	11.3
30	7.9	9.4
36	6.5	7.9
50	4.7	5.7
60	3.9	4.7
75	3.1	3.8
90	2.6	3.1
100	2.4	2.8
120	2.0	2.4
150	1.6	1.9
180	1.3	1.6

Further information

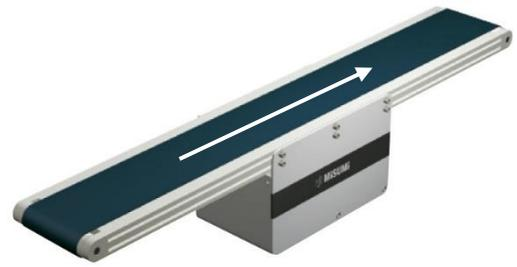
- Connection ▶ from page 43
- Belt characteristics ▶ from page 36
- Accessories ▶ from page 63

4.3.4 SVKRE

Special features

- Flat belt conveyors, single belt
- Pulley Ø 30 mm
- Central drive
- Belt with meandering prevention crosspiece

Technical data

Belt Width (mm) *	50~400				
Length (mm)*	390~3000				
Weight (kg)*	5.4~41.5				
Power output (W)*	6	25	40	60	90
Voltage (V)	230				
Frequency (Hz)	50				

* Specifications depend on the design of the conveyor

Conveyor Capacity

Permissible transfer mass (vertically in kg) as a function of belt speed (horizontal in m / min) and selected transmission ratio

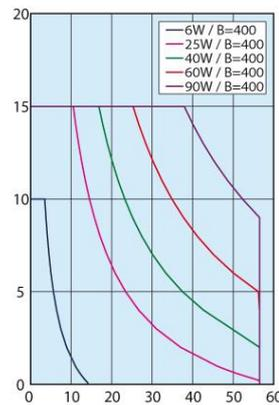
Gearhead reduction ratio

Belt speed (m / min) as a function of the frequency and the selected gearhead reduction ratio

	Belt speed	
	50 Hz	60 Hz
5	47.1	56.5
7.5	31.4	37.7
9	26.2	31.4
12.5	18.8	22.6
15	15.7	18.8
18	13.1	15.7
25	9.4	11.3
30	7.9	9.4
36	6.5	7.9
50	4.7	5.7
60	3.9	4.7
75	3.1	3.8
90	2.6	3.1
100	2.4	2.8
120	2.0	2.4
150	1.6	1.9
180	1.3	1.6

Further information

- Connection ▶ from page 43
- Belt characteristics ▶ from page 36
- Accessories ▶ from page 63

4.3.5 GVHAE

Special features

- Flat belt conveyors, single belt
- Pulley Ø 30 mm
- Head drive

Technical data

Belt Width (mm) *	30~300		
Length (mm)*	240~2000		
Weight (kg)*	3.9~15.1		
Power output (W)*	6	25	
Voltage (V)	230		
Frequency (Hz)	50		

* Specifications depend on the design of the conveyor

Conveyor Capacity

Permissible transfer mass (vertically in kg) as a function of belt speed (horizontal in m / min) and selected transmission ratio

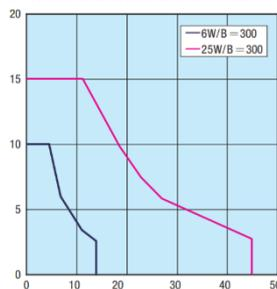
Gearhead reduction ratio

Belt speed (m / min) as a function of the frequency and the selected gearhead reduction ratio

	Belt speed	
	50 Hz	60 Hz
5	56.4	67.7
7.5	37.6	45.1
9	31.3	37.6
12.5	22.6	27.1
15	18.8	22.6
18	15.7	18.8
25	11.3	13.5
30	9.4	11.3
36	7.8	9.4
50	5.6	6.8
60	4.7	5.6
75	3.8	4.5
90	3.1	3.8
100	2.8	3.4
120	2.4	2.8
150	1.9	2.3
180	1.6	1.9

Further information

- Connection ▶ from page 43
- Belt characteristics ▶ from page 36
- Accessories ▶ from page 63

4.3.6 GVFAE

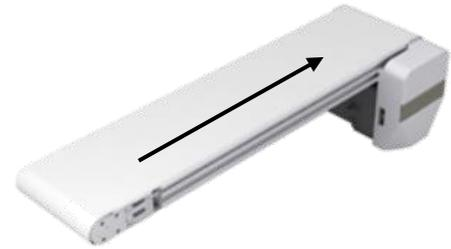
Special features

- Flat belt conveyors, single belt
- Pulley Ø 30 mm
- Head drive
- Full Belt

Technical data

Belt Width (mm) *	50~300		
Length (mm)*	240~2000		
Weight (kg)*	3.9~15.1		
Power output (W)*	6	25	
Voltage (V)	230		
Frequency (Hz)	50		

* Specifications depend on the design of the conveyor

Conveyor Capacity

Permissible transfer mass (vertically in kg) as a function of belt speed (horizontal in m / min) and selected transmission ratio

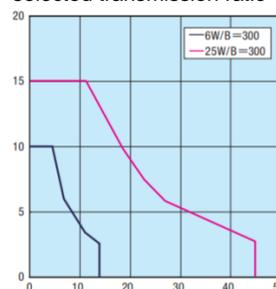
Gearhead reduction ratio

Belt speed (m / min) as a function of the frequency and the selected gearhead reduction ratio

	Belt speed	
	50 Hz	60 Hz
5	56.4	67.7
7.5	37.6	45.1
9	31.3	37.6
12.5	22.6	27.1
15	18.8	22.6
18	15.7	18.8
25	11.3	13.5
30	9.4	11.3
36	7.8	9.4
50	5.6	6.8
60	4.7	5.6
75	3.8	4.5
90	3.1	3.8
100	2.8	3.4
120	2.4	2.8
150	1.9	2.3
180	1.6	1.9

Further information

- Connection ▶ from page 43
- Belt characteristics ▶ from page 36
- Accessories ▶ from page 63

4.3.7 GVHNE

Special features

- Flat belt conveyors, single belt
- Pulley Ø 30 mm
- Central drive

Technical data

Belt Width (mm) *	30~300			
Length (mm)*	320~2000			
Weight (kg)*	7.8~24.1			
Power output (W)*	25	40	60	90
Voltage (V)	230			
Frequency (Hz)	50			

* Specifications depend on the design of the conveyor

Conveyor Capacity

Permissible transfer mass (vertically in kg) as a function of belt speed (horizontal in m / min) and selected transmission ratio

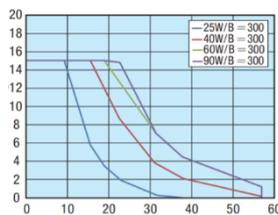
Gearhead reduction ratio

Belt speed (m / min) as a function of the frequency and the selected gearhead reduction ratio

	Belt speed	
	50 Hz	60 Hz
5	47.1	56.5
7.5	31.4	37.7
9	26.2	31.4
12.5	18.8	22.6
15	15.7	18.8
18	13.1	15.7
25	9.4	11.3
30	7.9	9.4
36	6.5	7.9
50	4.7	5.7
60	3.9	4.7
75	3.1	3.8
90	2.6	3.1
100	2.4	2.8
120	2	2.4
150	1.6	1.9
180	1.3	1.6

Further information

- Connection ▶ from page 43
- Belt characteristics ▶ from page 36
- Accessories ▶ from page 63

4.3.8 GVFNE

Special features

- Flat belt conveyors, single belt
- Pulley Ø 30 mm
- Central drive
- Full belt

Technical data

Belt Width (mm) *	50~300			
Length (mm)*	320~2000			
Weight (kg)*	7.8~24.1			
Power output (W)*	25	40	60	90
Voltage (V)	230			
Frequency (Hz)	50			

* Specifications depend on the design of the conveyor

Conveyor Capacity

Permissible transfer mass (vertically in kg) as a function of belt speed (horizontal in m / min) and selected transmission ratio

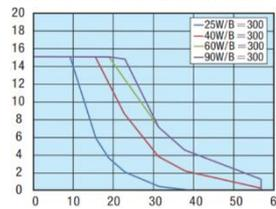
Gearhead reduction ratio

Belt speed (m / min) as a function of the frequency and the selected gearhead reduction ratio

	Belt speed	
	50 Hz	60 Hz
5	47.1	56.5
7.5	31.4	37.7
9	26.2	31.4
12.5	18.8	22.6
15	15.7	18.8
18	13.1	15.7
25	9.4	11.3
30	7.9	9.4
36	6.5	7.9
50	4.7	5.7
60	3.9	4.7
75	3.1	3.8
90	2.6	3.1
100	2.4	2.8
120	2	2.4
150	1.6	1.9
180	1.3	1.6

Further information

- Connection ▶ from page 43
- Belt characteristics ▶ from page 36
- Accessories ▶ from page 63

4.3.9 GVTSAE

Special features

- Timing belt conveyors, single belt
- Pulley Ø 30 mm
- Head drive

Technical data

Belt Width (mm) *	10
Length (mm)*	190~2000
Weight (kg)*	2.2~5.2
Power output (W)*	6 25
Voltage (V)	230
Frequency (Hz)	50

* Specifications depend on the design of the conveyor

Conveyor Capacity

Permissible transfer mass (vertically in kg) as a function of belt speed (horizontal in m / min) and selected transmission ratio

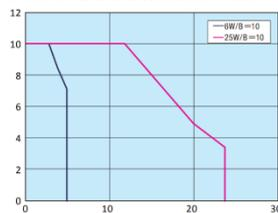
Gearhead reduction ratio

Belt speed (m / min) as a function of the frequency and the selected gearhead reduction ratio

	Belt speed	
	50 Hz	60 Hz
5	30.0	36.0
7.5	20.0	24.0
9	16.7	20.0
12.5	12.0	14.4
15	10.0	12.0
18	8.3	10.0
25	6.0	7.2
30	5.0	6.0
36	4.2	5.0
50	3.0	3.6
60	2.5	3.0
75	2.0	2.4
90	1.7	2.0
100	1.5	1.8
120	1.2	1.5
150	1.0	1.2
180	0.8	1.0

Further information

- Connection ▶ from page 43
- Belt characteristics ▶ from page 36
- Accessories ▶ from page 63

4.3.10 GVTSNE

Special features

- Timing belt conveyors, single belt
- Pulley Ø 30 mm
- Central drive

Technical data

Belt Width (mm) *	10
Length (mm)*	200~2000
Weight (kg)*	2.3~5.3
Power output (W)*	6 25
Voltage (V)	230
Frequency (Hz)	50

* Specifications depend on the design of the conveyor

Conveyor Capacity

Permissible transfer mass (vertically in kg) as a function of belt speed (horizontal in m / min) and selected transmission ratio

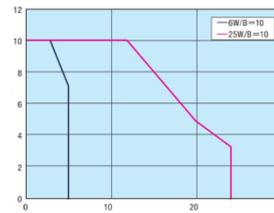
Gearhead reduction ratio

Belt speed (m / min) as a function of the frequency and the selected gearhead reduction ratio

	Belt speed	
	50 Hz	60 Hz
5	30.0	36.0
7.5	20.0	24.0
9	16.7	20.0
12.5	12.0	14.4
15	10.0	12.0
18	8.3	10.0
25	6.0	7.2
30	5.0	6.0
36	4.2	5.0
50	3.0	3.6
60	2.5	3.0
75	2.0	2.4
90	1.7	2.0
100	1.5	1.8
120	1.2	1.5
150	1.0	1.2
180	0.8	1.0

Further information

- Connection ▶ from page 43
- Belt characteristics ▶ from page 36
- Accessories ▶ from page 63

4.3.11 GVTWAUE

Special features

- Timing belt conveyors, double track
- Pulley Ø 30 mm
- Head drive (INSIDE the motor)

Technical data

Belt Width (mm) *	50~300		
Length (mm)*	250~2000		
Weight (kg)*	3.4~8.3		
Power output (W)*	6	25	
Voltage (V)	230		
Frequency (Hz)	50		

* Specifications depend on the design of the conveyor

Conveyor Capacity

Permissible transfer mass (vertically in kg) as a function of belt speed (horizontal in m / min) and selected transmission ratio

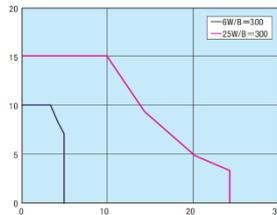
Gearhead reduction ratio

Belt speed (m / min) as a function of the frequency and the selected gearhead reduction ratio

	Belt speed	
	50 Hz	60 Hz
5	30.0	36.0
7.5	20.0	24.0
9	16.7	20.0
12.5	12.0	14.4
15	10.0	12.0
18	8.3	10.0
25	6.0	7.2
30	5.0	6.0
36	4.2	5.0
50	3.0	3.6
60	2.5	3.0
75	2.0	2.4
90	1.7	2.0
100	1.5	1.8
120	1.2	1.5
150	1.0	1.2
180	0.8	1.0

Further information

- Connection ▶ from page 43
- Belt characteristics ▶ from page 36
- Accessories ▶ from page 63

4.3.12 GVTWASE

Special features

- Timing belt conveyors, single belt
- Pulley Ø 30 mm
- Head drive (OUTSIDE the motor)

Technical data

Belt Width (mm) *	50~2300		
Length (mm)*	250~2000		
Weight (kg)*	3.4~8.3		
Power output (W)*	6	25	
Voltage (V)	230		
Frequency (Hz)	50		

* Specifications depend on the design of the conveyor

Conveyor Capacity

Permissible transfer mass (vertically in kg) as a function of belt speed (horizontal in m / min) and selected transmission ratio

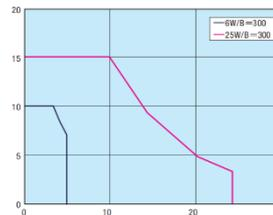
Gearhead reduction ratio

Belt speed (m / min) as a function of the frequency and the selected gearhead reduction ratio

	Belt speed	
	50 Hz	60 Hz
5	30.0	36.0
7.5	20.0	24.0
9	16.7	20.0
12.5	12.0	14.4
15	10.0	12.0
18	8.3	10.0
25	6.0	7.2
30	5.0	6.0
36	4.2	5.0
50	3.0	3.6
60	2.5	3.0
75	2.0	2.4
90	1.7	2.0
100	1.5	1.8
120	1.2	1.5
150	1.0	1.2
180	0.8	1.0

Further information

- Connection ▶ from page 43
- Belt characteristics ▶ from page 36
- Accessories ▶ from page 63

4.3.13 GVTWNUE

Special features

- Timing belt conveyors, double track
- Pulley Ø 30 mm
- Central drive (INSIDE the motor)

Technical data

Belt Width (mm) *	50~300		
Length (mm)*	280~2000		
Weight (kg)*	3.5~8.5		
Power output (W)*	6	25	
Voltage (V)	230		
Frequency (Hz)	50		

* Specifications depend on the design of the conveyor

Conveyor Capacity

Permissible transfer mass (vertically in kg) as a function of belt speed (horizontal in m / min) and selected transmission ratio

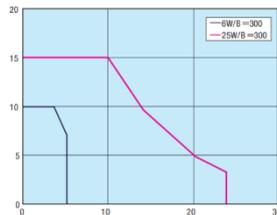
Gearhead reduction ratio

Belt speed (m / min) as a function of the frequency and the selected gearhead reduction ratio

	Belt speed	
	50 Hz	60 Hz
5	30.0	36.0
7.5	20.0	24.0
9	16.7	20.0
12.5	12.0	14.4
15	10.0	12.0
18	8.3	10.0
25	6.0	7.2
30	5.0	6.0
36	4.2	5.0
50	3.0	3.6
60	2.5	3.0
75	2.0	2.4
90	1.7	2.0
100	1.5	1.8
120	1.2	1.5
150	1.0	1.2
180	0.8	1.0

Further information

- Connection ▶ from page 43
- Belt characteristics ▶ from page 36
- Accessories ▶ from page 63

4.3.14 GVTWNSE

Special features

- Timing belt conveyors, double track
- Pulley Ø 30 mm
- Central drive (OUTSIDE the motor)

Technical data

Belt Width (mm) *	50~300		
Length (mm)*	280~2000		
Weight (kg)*	3.5~8.5		
Power output (W)*	6	25	
Voltage (V)	230		
Frequency (Hz)	50		

* Specifications depend on the design of the conveyor

Conveyor Capacity

Permissible transfer mass (vertically in kg) as a function of belt speed (horizontal in m / min) and selected transmission ratio

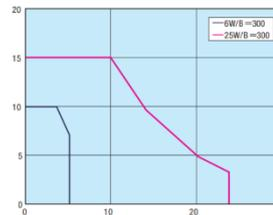
Gearhead reduction ratio

Belt speed (m / min) as a function of the frequency and the selected gearhead reduction ratio

	Belt speed	
	50 Hz	60 Hz
5	30.0	36.0
7.5	20.0	24.0
9	16.7	20.0
12.5	12.0	14.4
15	10.0	12.0
18	8.3	10.0
25	6.0	7.2
30	5.0	6.0
36	4.2	5.0
50	3.0	3.6
60	2.5	3.0
75	2.0	2.4
90	1.7	2.0
100	1.5	1.8
120	1.2	1.5
150	1.0	1.2
180	0.8	1.0

Further information

- Connection ▶ from page 43
- Belt characteristics ▶ from page 36
- Accessories ▶ from page 63

4.3.15 CVGAE

Special features

- Flat belt conveyors, single belt
- Pulley Ø 30 mm
- Head drive
- Width of transport surface

Technical data

Belt Width (mm) *	30~300		
Length (mm)*	190~2000		
Weight (kg)*	4.2~17.4		
Power output (W)*	6	25	
Voltage (V)	230		
Frequency (Hz)	50		

* Specifications depend on the design of the conveyor

Conveyor Capacity

Permissible transfer mass (vertically in kg) as a function of belt speed (horizontal in m / min) and selected transmission ratio

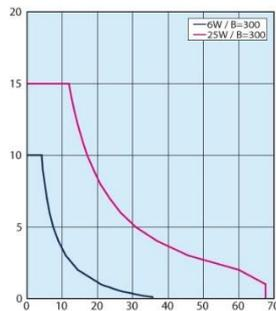
Gearhead reduction ratio

Belt speed (m / min) as a function of the frequency and the selected gearhead reduction ratio

	Belt speed	
	50 Hz	60 Hz
5	56.4	67.7
7.5	37.6	45.1
9	31.3	31.6
12.5	22.6	27.1
15	18.8	22.6
18	15.7	18.8
25	11.3	13.5
30	9.4	11.3
36	7.8	9.4
50	5.6	6.8
60	4.7	5.6
75	3.8	4.5
90	3.1	3.8
100	2.8	3.4
120	2.4	2.8
150	1.9	2.3
180	1.6	1.9

Further information

- Connection ▶ from page 43
- Belt characteristics ▶ from page 36
- Accessories ▶ from page 63

4.3.16 CVGCE

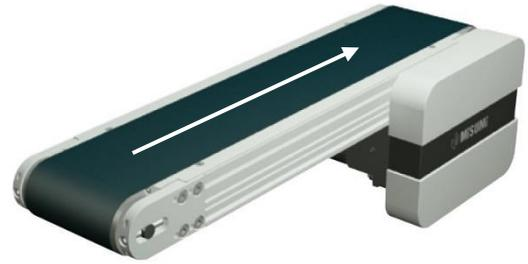
Special features

- Flat belt conveyors, single belt
- Pulley Ø 50 mm
- Head drive
- Width of transport surface

Technical data

Belt Width (mm) *	40~300		
Length (mm)*	240~2000		
Weight (kg)*	6.5~25.7		
Power output (W)*	6	25	40
Voltage (V)	230		
Frequency (Hz)	50		

* Specifications depend on the design of the conveyor

Conveyor Capacity

Permissible transfer mass (vertically in kg) as a function of belt speed (horizontal in m / min) and selected transmission ratio

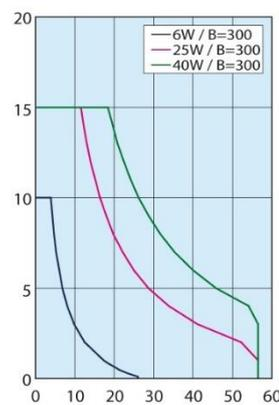
Gearhead reduction ratio

Belt speed (m / min) as a function of the frequency and the selected gearhead reduction ratio

	Belt speed	
	50 Hz	60 Hz
5	47.1	56.5
7.5	31.4	37.7
9	26.2	31.4
12.5	18.8	22.6
15	15.7	18.8
18	13.1	15.7
25	9.4	11.3
30	7.9	9.4
36	6.5	7.9
50	4.7	5.7
60	3.9	4.7
75	3.1	3.8
90	2.6	3.1
100	2.4	2.8
120	2.0	2.4
150	1.6	1.9
180	1.3	1.6

Further information

- Connection ▶ from page 43
- Belt characteristics ▶ from page 36
- Accessories ▶ from page 63

4.3.17 CVGNE

Special features

- Flat belt conveyors, single belt
- Pulley Ø 30 mm
- Central drive
- Adjustable belt tension

Technical data

Belt Width (mm) *	30~300		
Length (mm)*	355~2000		
Weight (kg)*	5.8~23.9		
Power output (W)*	6	25	
Voltage (V)	230		
Frequency (Hz)	50		

* Specifications depend on the design of the conveyor

Conveyor Capacity

Permissible transfer mass (vertically in kg) as a function of belt speed (horizontal in m / min) and selected transmission ratio

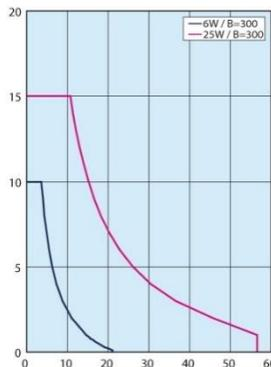
Gearhead reduction ratio

Belt speed (m / min) as a function of the frequency and the selected gearhead reduction ratio

	Belt speed	
	50 Hz	60 Hz
5	47.1	56.5
7.5	31.4	37.7
9	26.2	31.4
12.5	18.8	22.6
15	15.7	18.8
18	13.1	15.7
25	9.4	11.3
30	7.9	9.4
36	6.5	7.9
50	4.7	5.7
60	3.9	4.7
75	3.1	3.8
90	2.6	3.1
100	2.4	2.8
120	2.0	2.4
150	1.6	1.9
180	1.3	1.6

Further information

- Connection ▶ from page 43
- Belt characteristics ▶ from page 36
- Accessories ▶ from page 63

4.3.18 CVGRE

Special features

- Flat belt conveyors, single belt
- Pulley Ø 50 mm
- Central drive
- Adjustable belt tension

Technical data

Belt Width (mm) *	40~300		
Length (mm)*	385~2000		
Weight (kg)*	7.3~30.6		
Power output (W)*	6	25	40
Voltage (V)	230		
Frequency (Hz)	50		

* Specifications depend on the design of the conveyor

Conveyor Capacity

Permissible transfer mass (vertically in kg) as a function of belt speed (horizontal in m / min) and selected transmission ratio

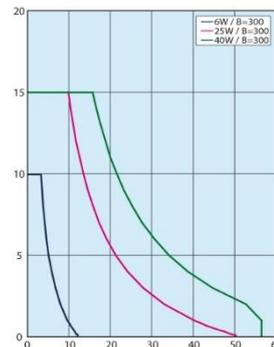
Gearhead reduction ratio

Belt speed (m / min) as a function of the frequency and the selected gearhead reduction ratio

	Belt speed	
	50 Hz	60 Hz
5	47.1	56.5
7.5	31.4	37.7
9	26.2	31.4
12.5	18.8	22.6
15	15.7	18.8
18	13.1	15.7
25	9.4	11.3
30	7.9	9.4
36	6.5	7.9
50	4.7	5.7
60	3.9	4.7
75	3.1	3.8
90	2.6	3.1
100	2.4	2.8
120	2.0	2.4
150	1.6	1.9
180	1.3	1.6

Further information

- Connection ▶ from page 43
- Belt characteristics ▶ from page 36
- Accessories ▶ from page 63

4.3.19 CVGBE

Special features

- Flat belt conveyors, single belt
- Pulley Ø 30 mm
- Head drive
- Belt with meandering prevention crosspiece

Technical data

Belt Width (mm) *	50~300		
Length (mm)*	190~2000		
Weight (kg)*	4.2~17.4		
Power output (W)*	6	25	
Voltage (V)	230		
Frequency (Hz)	50		

* Specifications depend on the design of the conveyor

Conveyor Capacity

Permissible transfer mass (vertically in kg) as a function of belt speed (horizontal in m / min) and selected transmission ratio

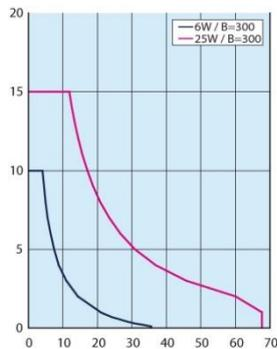
Gearhead reduction ratio

Belt speed (m / min) as a function of the frequency and the selected gearhead reduction ratio

	Belt speed	
	50 Hz	60 Hz
5	56.4	67.7
7.5	37.6	45.1
9	31.3	37.6
12.5	22.6	27.1
15	18.8	22.6
18	15.7	18.8
25	11.3	13.5
30	9.4	11.3
36	7.8	9.4
50	5.6	6.8
60	4.7	5.6
75	3.8	4.5
90	3.1	3.8
100	2.8	3.4
120	2.4	2.8
150	1.9	2.3
180	1.6	1.9

Further information

- Connection ▶ from page 43
- Belt characteristics ▶ from page 36
- Accessories ▶ from page 63

4.3.20 CVGDE

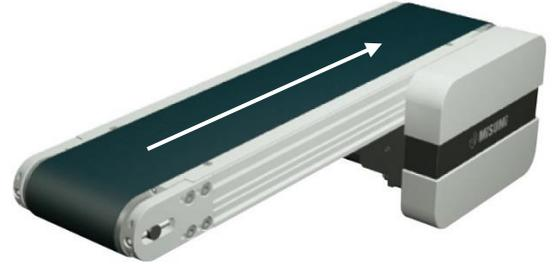
Special features

- Flat belt conveyors, single belt
- Pulley Ø 50 mm
- Head drive
- Belt with meandering prevention crosspiece

Technical data

Belt Width (mm) *	50~300		
Length (mm)*	240~2000		
Weight (kg)*	6.5~25.7		
Power output (W)*	6	25	40
Voltage (V)	230		
Frequency (Hz)	50		

* Specifications depend on the design of the conveyor

Conveyor Capacity

Permissible transfer mass (vertically in kg) as a function of belt speed (horizontal in m / min) and selected transmission ratio

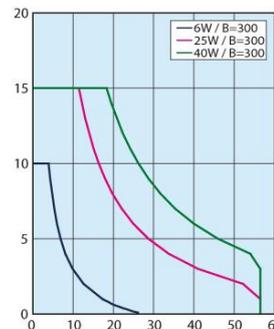
Gearhead reduction ratio

Belt speed (m / min) as a function of the frequency and the selected gearhead reduction ratio

	Belt speed	
	50 Hz	60 Hz
5	47.1	56.5
7.5	31.4	37.7
9	26.2	31.4
12.5	18.8	22.6
15	15.7	18.8
18	13.1	15.7
25	9.4	11.3
30	7.9	9.4
36	6.5	7.9
50	4.7	5.7
60	3.9	4.7
75	3.1	3.8
90	2.6	3.1
100	2.4	2.8
120	2.0	2.4
150	1.6	1.9
180	1.3	1.6

Further information

- Connection ▶ from page 43
- Belt characteristics ▶ from page 36
- Accessories ▶ from page 63

4.3.21 CVGPE

Special features

- Flat belt conveyors, single belt
- Pulley Ø 30 mm
- Central drive
- Belt with meandering prevention crosspiece

Technical data

Belt Width (mm) *	50~300		
Length (mm)*	300~2000		
Weight (kg)*	5.8~23.9		
Power output (W)*	6	25	
Voltage (V)	230		
Frequency (Hz)	50		

* Specifications depend on the design of the conveyor

Conveyor Capacity

Permissible transfer mass (vertically in kg) as a function of belt speed (horizontal in m / min) and selected transmission ratio

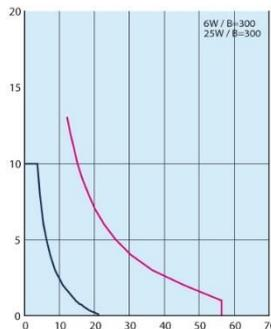
Gearhead reduction ratio

Belt speed (m / min) as a function of the frequency and the selected gearhead reduction ratio

	Belt speed	
	50 Hz	60 Hz
5	47.1	56.5
7.5	31.4	37.7
9	26.2	31.4
12.5	18.8	22.6
15	15.7	18.8
18	13.1	15.7
25	9.4	11.3
30	7.9	9.4
36	6.5	7.9
50	4.7	5.7
60	3.9	4.7
75	3.1	3.8
90	2.6	3.1
100	2.4	2.8
120	2.0	2.4
150	1.6	1.9
180	1.3	1.6

Further information

- Connection ▶ from page 43
- Belt characteristics ▶ from page 36
- Accessories ▶ from page 63

4.3.22 CVGWE

Special features

- Flat belt conveyors, single belt
- Pulley Ø 50 mm
- Central drive
- Belt with meandering prevention crosspiece

Technical data

Belt Width (mm) *	50~300		
Length (mm)*	385~2000		
Weight (kg)*	7.3~30.6		
Power output (W)*	6	25	40
Voltage (V)	230		
Frequency (Hz)	50		

* Specifications depend on the design of the conveyor

Conveyor Capacity

Permissible transfer mass (vertically in kg) as a function of belt speed (horizontal in m / min) and selected transmission ratio

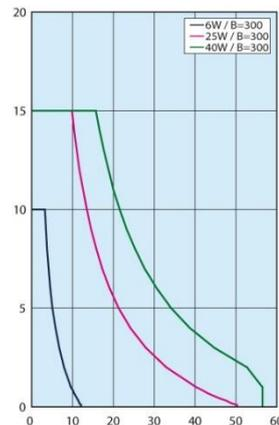
Gearhead reduction ratio

Belt speed (m / min) as a function of the frequency and the selected gearhead reduction ratio

	Belt speed	
	50 Hz	60 Hz
5	47.1	56.5
7.5	31.4	37.7
9	26.2	31.4
12.5	18.8	22.6
15	15.7	18.8
18	13.1	15.7
25	9.4	11.3
30	7.9	9.4
36	6.5	7.9
50	4.7	5.7
60	3.9	4.7
75	3.1	3.8
90	2.6	3.1
100	2.4	2.8
120	2.0	2.4
150	1.6	1.9
180	1.3	1.6

Further information

- Connection ▶ from page 43
- Belt characteristics ▶ from page 36
- Accessories ▶ from page 63

4.3.23 CVSEE

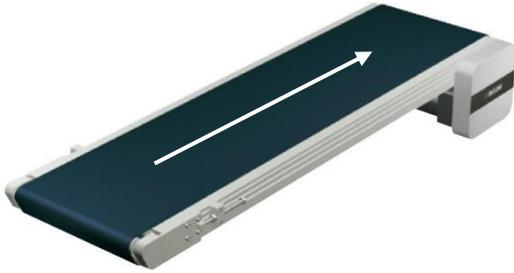
Special features

- Flat belt conveyors, single belt, high power
- Pulley Ø 30, 60 mm
- Head drive
- Medium conveying length

Technical data

Belt Width (mm) *	100~500	
Length (mm)*	440~6000	
Weight (kg)*	15.9~81.5	
Power output (W)*	60	90
Voltage (V)	230	
Frequency (Hz)	50	

* Specifications depend on the design of the conveyor

Conveyor Capacity

Permissible transfer mass (vertically in kg) as a function of belt speed (horizontal in m / min) and selected transmission ratio

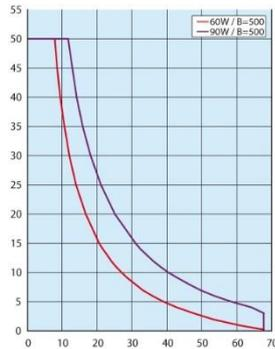
Gearhead reduction ratio

Belt speed (m / min) as a function of the frequency and the selected gearhead reduction ratio

	Belt speed	
	50 Hz	60 Hz
5	56.4	67.7
7.5	37.6	45.1
9	31.3	37.6
12.5	22.6	27.1
15	18.8	22.6
18	15.7	18.8
25	11.3	13.5
30	9.4	11.3
36	7.8	9.4
50	5.6	6.8
60	4.7	5.6
75	3.8	4.5
90	3.1	3.8
100	2.8	3.4
120	2.4	2.8
150	1.9	2.3
180	1.6	1.9



Further information
 Connection
 Belt characteristics
 Accessories

- ▶ from page 43
- ▶ from page 36
- ▶ from page 63

4.3.24 CVSFE

Special features

- Flat belt conveyors, single belt, high power
- Pulley Ø 30, 60 mm
- Head drive
- Belt with meandering prevention crosspiece

Technical data

Belt Width (mm) *	100~500	
Length (mm)*	440~6000	
Weight (kg)*	15.9~81.5	
Power output (W)*	60	90
Voltage (V)	230	
Frequency (Hz)	50	

* Specifications depend on the design of the conveyor

Conveyor Capacity

Permissible transfer mass (vertically in kg) as a function of belt speed (horizontal in m / min) and selected transmission ratio

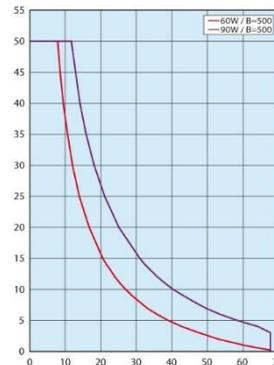
Gearhead reduction ratio

Belt speed (m / min) as a function of the frequency and the selected gearhead reduction ratio

	Belt speed	
	50 Hz	60 Hz
5	56.4	67.7
7.5	37.6	45.1
9	31.3	37.6
12.5	22.6	27.1
15	18.8	22.6
18	15.7	18.8
25	11.3	13.5
30	9.4	11.3
36	7.8	9.4
50	5.6	6.8
60	4.7	5.6
75	3.8	4.5
90	3.1	3.8
100	2.8	3.4
120	2.4	2.8
150	1.9	2.3
180	1.6	1.9

Further information

Connection
 Belt characteristics
 Accessories

- ▶ from page 43
- ▶ from page 36
- ▶ from page 63

4.3.25 CVSXE

Special features

- Flat belt conveyors, single belt, high power
- Pulley Ø 30 mm
- Central drive
- Medium conveying length

Technical data

Belt Width (mm) *	100–500	
Length (mm)*	480–6000	
Weight (kg)*	20–94	
Power output (W)*	60	90
Voltage (V)	230	
Frequency (Hz)	50	

* Specifications depend on the design of the conveyor

Conveyor Capacity

Permissible transfer mass (vertically in kg) as a function of belt speed (horizontal in m / min) and selected transmission ratio

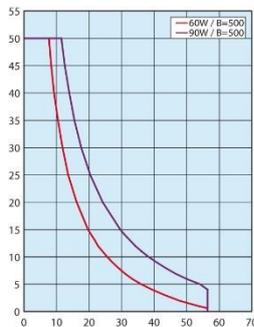
Gearhead reduction ratio

Belt speed (m / min) as a function of the frequency and the selected gearhead reduction ratio

	Belt speed	
	50 Hz	60 Hz
5	47.1	56.5
7.5	31.4	37.7
9	26.2	31.4
12.5	18.8	22.6
15	15.7	18.8
18	13.1	15.7
25	9.4	11.3
30	7.9	9.4
36	6.5	7.9
50	4.7	5.7
60	3.9	4.7
75	3.1	3.8
90	2.6	3.1
100	2.4	2.8
120	2.0	2.4
150	1.6	1.9
180	1.3	1.6

Further information

- Connection ▶ from page 43
- Belt characteristics ▶ from page 36
- Accessories ▶ from page 63

4.3.26 CVSYE

Special features

- Flat belt conveyors, single belt, high power
- Pulley Ø 30 mm
- Central drive
- Belt with meandering prevention crosspiece

Technical data

Belt Width (mm) *	100–500	
Length (mm)*	480–6000	
Weight (kg)*	20–94	
Power output (W)*	60	90
Voltage (V)	230	
Frequency (Hz)	50	

* Specifications depend on the design of the conveyor

Conveyor Capacity

Permissible transfer mass (vertically in kg) as a function of belt speed (horizontal in m / min) and selected transmission ratio

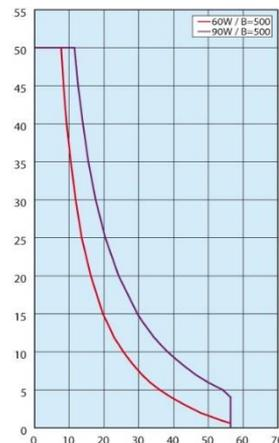
Gearhead reduction ratio

Belt speed (m / min) as a function of the frequency and the selected gearhead reduction ratio

	Belt speed	
	50 Hz	60 Hz
5	47.1	56.5
7.5	31.4	37.7
9	26.2	31.4
12.5	18.8	22.6
15	15.7	18.8
18	13.1	15.7
25	9.4	11.3
30	7.9	9.4
36	6.5	7.9
50	4.7	5.7
60	3.9	4.7
75	3.1	3.8
90	2.6	3.1
100	2.4	2.8
120	2.0	2.4
150	1.6	1.9
180	1.3	1.6

Further information

- Connection ▶ from page 43
- Belt characteristics ▶ from page 36
- Accessories ▶ from page 63

4.3.27 CVSFAE

Special features

- Full-belt conveyors, single belt
- Pulley Ø 30 mm
- Head drive
- Total surface area usable for transport

Technical data

Belt Width (mm) *	60~300		
Length (mm)*	280~2000		
Weight (kg)*	4.3~16.3		
Power output (W)*	6	25	
Voltage (V)	230		
Frequency (Hz)	50		

* Specifications depend on the design of the conveyor

Conveyor Capacity

Permissible transfer mass (vertically in kg) as a function of belt speed (horizontal in m / min) and selected transmission ratio

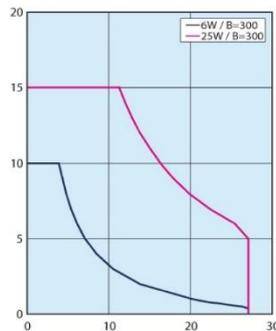
Gearhead reduction ratio

Belt speed (m / min) as a function of the frequency and the selected gearhead reduction ratio

	Belt speed	
	50 Hz	60 Hz
12.5	22.6	27.1
15	18.8	22.6
18	15.7	18.8
25	11.3	13.5
30	9.4	11.3
36	7.8	9.4
50	5.6	6.8
60	4.7	5.6
75	3.8	4.5
90	3.1	3.8
100	2.8	3.4
120	2.4	2.8
150	1.9	2.3
180	1.6	1.9

Further information

- Connection ▶ from page 43
- Belt characteristics ▶ from page 36
- Accessories ▶ from page 63

4.3.28 CVSFBF

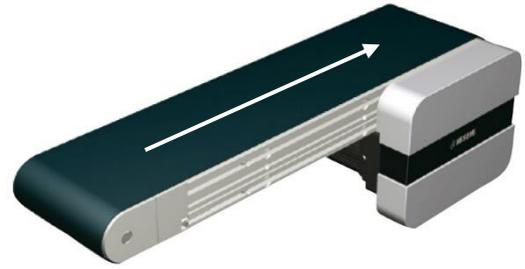
Special features

- Full-belt conveyors, single belt
- Pulley Ø 50 mm
- Head drive
- Total surface area usable for transport

Technical data

Belt Width (mm) *	60~300		
Length (mm)*	320~2000		
Weight (kg)*	6~23.9		
Power output (W)*	6	25	40
Voltage (V)	230		
Frequency (Hz)	50		

* Specifications depend on the design of the conveyor

Conveyor Capacity

Permissible transfer mass (vertically in kg) as a function of belt speed (horizontal in m / min) and selected transmission ratio

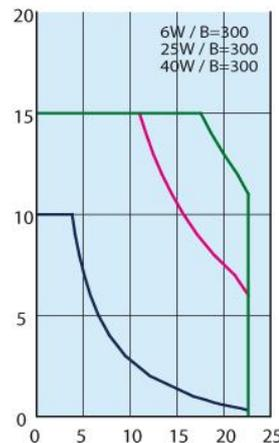
Gearhead reduction ratio

Belt speed (m / min) as a function of the frequency and the selected gearhead reduction ratio

	Belt speed	
	50 Hz	60 Hz
12.5	18.8	22.6
15	15.7	18.8
18	13.1	15.7
25	9.4	11.3
30	7.9	9.4
36	6.5	7.9
50	4.7	5.7
60	3.9	4.7
75	3.1	3.8
90	2.6	3.1
100	2.4	2.8
120	2.0	2.4
150	1.6	1.9
180	1.3	1.6

Further information

- Connection ▶ from page 43
- Belt characteristics ▶ from page 36
- Accessories ▶ from page 63

4.3.29 CVSFCE

Special features

- Full-belt conveyors, single belt
- Pulley Ø 30 mm
- Head drive
- Belt with meandering prevention crosspiece
- Total surface area usable for transport

Technical data

Belt Width (mm) *	70~300		
Length (mm)*	280~2000		
Weight (kg)*	4.3~16.3		
Power output (W)*	6	25	
Voltage (V)	230		
Frequency (Hz)	50		

* Specifications depend on the design of the conveyor

Conveyor Capacity

Permissible transfer mass (vertically in kg) as a function of belt speed (horizontal in m / min) and selected transmission ratio

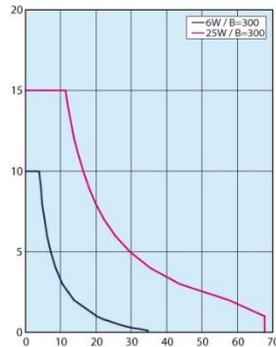
Gearhead reduction ratio

Belt speed (m / min) as a function of the frequency and the selected gearhead reduction ratio

	Belt speed	
	50 Hz	60 Hz
5	56.4	67.7
7.5	37.6	45.1
9	31.3	37.6
12.5	22.6	27.1
15	18.8	22.6
18	15.7	18.8
25	11.3	13.5
30	9.4	11.3
36	7.8	9.4
50	5.6	6.8
60	4.7	5.6
75	3.8	4.5
90	3.1	3.8
100	2.8	3.4
120	2.4	2.8
150	1.9	2.3
180	1.6	1.9

Further information

- Connection ▶ from page 43
- Belt characteristics ▶ from page 36
- Accessories ▶ from page 63

4.3.30 CVSFDE

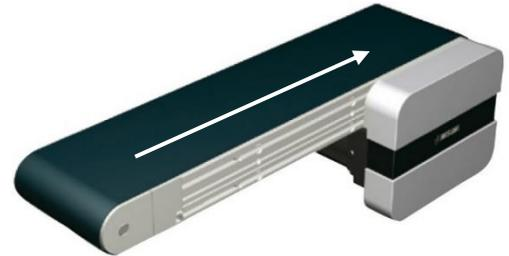
Special features

- Full-belt conveyors, single belt
- Pulley Ø 50 mm
- Head drive
- Belt with meandering prevention crosspiece
- Total surface area usable for transport

Technical data

Belt Width (mm) *	80~300		
Length (mm)*	320~2000		
Weight (kg)*	6~23.9		
Power output (W)*	6	25	40
Voltage (V)	230		
Frequency (Hz)	50		

* Specifications depend on the design of the conveyor

Conveyor Capacity

Permissible transfer mass (vertically in kg) as a function of belt speed (horizontal in m / min) and selected transmission ratio

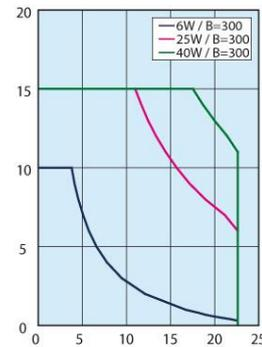
Gearhead reduction ratio

Belt speed (m / min) as a function of the frequency and the selected gearhead reduction ratio

	Belt speed	
	50 Hz	60 Hz
5	47.1	56.5
7.5	31.4	37.7
9	26.2	31.4
12.5	18.8	22.6
15	15.7	18.8
18	13.1	15.7
25	9.4	11.3
30	7.9	9.4
36	6.5	7.9
50	4.7	5.7
60	3.9	4.7
75	3.1	3.8
90	2.6	3.1
100	2.4	2.8
120	2.0	2.4
150	1.6	1.9
180	1.3	1.6

Further information

- Connection ▶ from page 43
- Belt characteristics ▶ from page 36
- Accessories ▶ from page 63

4.3.31 CVSJAE

Special features

- Flat belt conveyors, single belt
- Pulley Ø 30 mm
- Central drive
- Belt with meandering prevention crosspiece

Technical data

Belt Width (mm) *	50~300	
Length (mm)*	220~600	
Weight (kg)*	6.7~14.3	
Power output (W)*	6	25
Voltage (V)	230	
Frequency (Hz)	50	

* Specifications depend on the design of the conveyor

Conveyor Capacity

Permissible transfer mass (vertically in kg) as a function of belt speed (horizontal in m / min) and selected transmission ratio

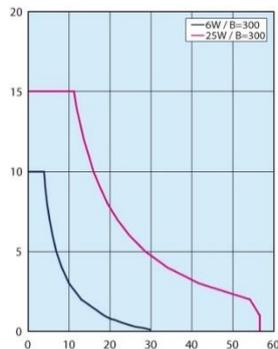
Gearhead reduction ratio

Belt speed (m / min) as a function of the frequency and the selected gearhead reduction ratio

	Belt speed	
	50 Hz	60 Hz
5	47.1	56.5
7.5	31.4	37.7
9	26.2	31.4
12.5	18.8	22.6
15	15.7	18.8
18	13.1	15.7
25	9.4	11.3
30	7.9	9.4
36	6.5	7.9
50	4.7	5.7
60	3.9	4.7
75	3.1	3.8
90	2.6	3.1
100	2.4	2.8
120	2.0	2.4
150	1.6	1.9
180	1.3	1.6

Further information

- Connection ▶ from page 43
- Belt characteristics ▶ from page 36
- Accessories ▶ from page 63

4.3.32 CVSMAE

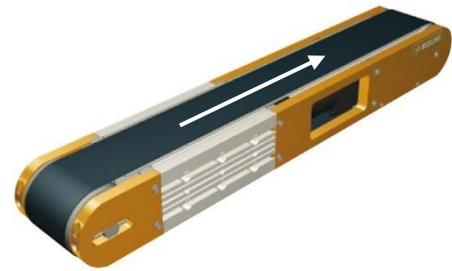
Special features

- Flat belt conveyors, single belt, short design
- Pulley Ø 70 mm
- Integrated drive
- Reduced conveyor height

Technical data

Belt Width (mm) *	60, 100, 150	
Length (mm)*	415~2000	
Weight (kg)*	6.2~18.7	
Power output (W)*	6	
Voltage (V)	230	
Frequency (Hz)	50	

* Specifications depend on the design of the conveyor

Conveyor Capacity

Permissible transfer mass (vertically in kg) as a function of belt speed (horizontal in m / min) and selected transmission ratio

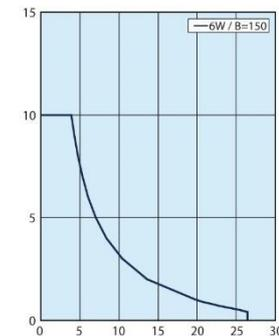
Gearhead reduction ratio

Belt speed (m / min) as a function of the frequency and the selected gearhead reduction ratio

	Belt speed	
	50 Hz	60 Hz
15	22.0	26.4
18	18.3	22.0
25	13.2	15.8
30	11.0	13.2
36	9.2	11.0
50	6.6	7.9
60	5.5	6.6
75	4.4	5.3
90	3.7	4.4
100	3.3	4.0
120	2.7	3.3
150	2.2	2.6
180	1.8	2.2

Further information

- Connection ▶ from page 43
- Belt characteristics ▶ from page 36
- Accessories ▶ from page 63

4.3.33 CVLP AE

Special features

- Flat belt conveyors, single belt
- Pulley Ø 15 mm
- Central drive
- Low design

Technical data

Belt Width (mm) *	60~200	
Length (mm)*	390~2000	
Weight (kg)*	7.6~21.1	
Power output (W)*	25	40
Voltage (V)	230	
Frequency (Hz)	50	

* Specifications depend on the design of the conveyor

Conveyor Capacity

Permissible transfer mass (vertically in kg) as a function of belt speed (horizontal in m / min) and selected transmission ratio

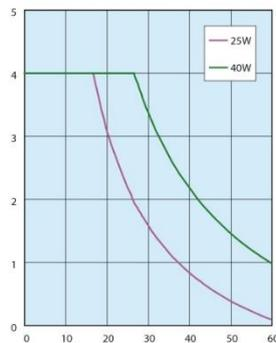
Gearhead reduction ratio

Belt speed (m / min) as a function of the frequency and the selected gearhead reduction ratio

	Belt speed	
	50 Hz	60 Hz
5	47.1	56.5
7.5	31.4	37.7
9	26.2	31.4
12.5	18.8	22.6
15	15.7	18.8
18	13.1	15.7
25	9.4	11.3
30	7.9	9.4
36	6.5	7.9
50	4.7	5.7
60	3.9	4.7
75	3.1	3.8
90	2.6	3.1
100	2.4	2.8
120	2.0	2.4
150	1.6	1.9
180	1.3	1.6

Further information

- Connection ▶ from page 43
- Belt characteristics ▶ from page 36
- Accessories ▶ from page 63

4.3.34 CVMAE

Special features

- Flat belt conveyors, single belt
- Pulley Ø 30 mm
- Head drive
- Selectable motor position

Technical data

Belt Width (mm) *	50~300	
Length (mm)*	200~2000	
Weight (kg)*	10.5~20	
Power output (W)*	25	40
Voltage (V)	230	
Frequency (Hz)	50	

* Specifications depend on the design of the conveyor

Conveyor Capacity

Permissible transfer mass (vertically in kg) as a function of belt speed (horizontal in m / min) and selected transmission ratio

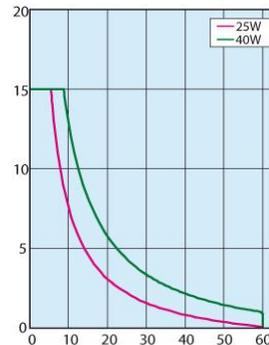
Gearhead reduction ratio

Belt speed (m / min) as a function of the frequency and the selected gearhead reduction ratio

	Belt speed	
	50 Hz	60 Hz
5	56.4	67.7
7.5	37.6	45.1
9	31.3	37.6
12.5	22.6	27.1
15	18.8	22.6
18	15.7	18.8
25	11.3	13.5
30	9.4	11.3
36	7.8	9.4
50	5.6	6.8
60	4.7	5.6
75	3.8	4.5
90	3.1	3.8
100	2.8	3.4
120	2.4	2.8
150	1.9	2.3
180	1.6	1.9

Further information

- Connection ▶ from page 43
- Belt characteristics ▶ from page 36
- Accessories ▶ from page 63

4.3.35 CVMBE

Special features

- Flat belt conveyors, single belt
- Pulley Ø 30 mm
- Head drive
- Belt with meandering prevention crosspiece

Technical data

Belt Width (mm) *	50~300	
Length (mm)*	200~2000	
Weight (kg)*	10.5~20	
Power output (W)*	25	40
Voltage (V)	230	
Frequency (Hz)	50	

* Specifications depend on the design of the conveyor

Conveyor Capacity

Permissible transfer mass (vertically in kg) as a function of belt speed (horizontal in m / min) and selected transmission ratio

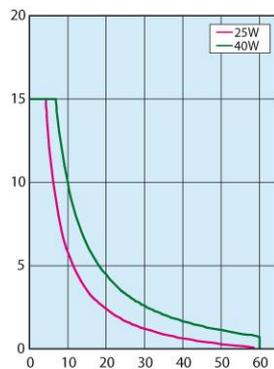
Gearhead reduction ratio

Belt speed (m / min) as a function of the frequency and the selected gearhead reduction ratio

	Belt speed	
	50 Hz	60 Hz
5	56.4	67.7
7.5	37.6	45.1
9	31.3	37.6
12.5	22.6	27.1
15	18.8	22.6
18	15.7	18.8
25	11.3	13.5
30	9.4	11.3
36	7.8	9.4
50	5.6	6.8
60	4.7	5.6
75	3.8	4.5
90	3.1	3.8
100	2.8	3.4
120	2.4	2.8
150	1.9	2.3
180	1.6	1.9

Further information

- Connection ▶ from page 43
- Belt characteristics ▶ from page 36
- Accessories ▶ from page 63

4.3.36 CVSTCE

Special features

- Timing belt conveyors, single belt
- Pulley Ø 19, 20 mm
- Head drive
- Space-saving design

Technical data

Belt Width (mm) *	10, 20	
Length (mm)*	245~2000	
Weight (kg)*	3~7.7	
Power output (W)*	6	
Voltage (V)	230	
Frequency (Hz)	50	

* Specifications depend on the design of the conveyor

Conveyor Capacity

Permissible transfer mass (vertically in kg) as a function of belt speed (horizontal in m / min) and selected transmission ratio

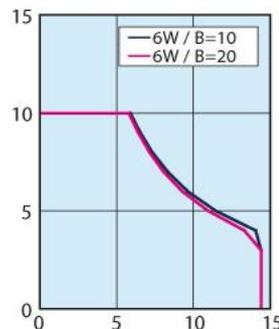
Gearhead reduction ratio

Belt speed (m / min) as a function of the frequency and the selected gearhead reduction ratio

	Belt speed	
	50 Hz	60 Hz
12.5	12.0	14.4
15	10.0	12.0
18	8.3	10.0
25	6.0	7.2
30	5.0	6.0
36	4.2	5.0
50	3.0	3.6
60	2.5	3.0
75	2.0	2.4
90	1.7	2.0
100	1.5	1.8
120	1.3	1.5
150	1.0	1.2
180	0.8	1.0

Further information

- Connection ▶ from page 43
- Belt characteristics ▶ from page 36
- Accessories ▶ from page 63

4.3.37 CVSTRE

Special features

- Timing belt conveyors, single belt
- Pulley Ø 19, 20 mm
- Central drive
- Space-saving design

Technical data

Belt Width (mm) *	10, 20
Length (mm)*	330~2000
Weight (kg)*	3.9~8.6
Power output (W)*	6
Voltage (V)	230
Frequency (Hz)	50

* Specifications depend on the design of the conveyor

Conveyor Capacity

Permissible transfer mass (vertically in kg) as a function of belt speed (horizontal in m / min) and selected transmission ratio

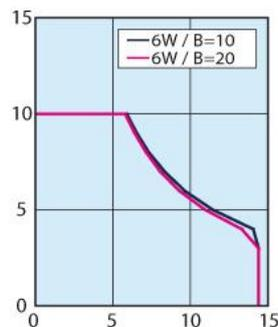
Gearhead reduction ratio

Belt speed (m / min) as a function of the frequency and the selected gearhead reduction ratio

	Belt speed	
	50 Hz	60 Hz
12.5	12.0	14.4
15	10.0	12.0
18	8.3	10.0
25	6.0	7.2
30	5.0	6.0
36	4.2	5.0
50	3.0	3.6
60	2.5	3.0
75	2.0	2.4
90	1.7	2.0
100	1.5	1.8
120	1.3	1.5
150	1.0	1.2
180	0.8	1.0

4.3.38 CVGTAE

Special features

- Timing belt conveyors, double track
- Pulley Ø 30 mm
- Head drive
- Stoppers, sensors can be installed in the gap

Technical data

Belt Width (mm) *	80~300	
Length (mm)*	255~3000	
Weight (kg)*	5.2~10.6	
Power output (W)*	6	25
Voltage (V)	230	
Frequency (Hz)	50	

* Specifications depend on the design of the conveyor

Conveyor Capacity

Permissible transfer mass (vertically in kg) as a function of belt speed (horizontal in m / min) and selected transmission ratio

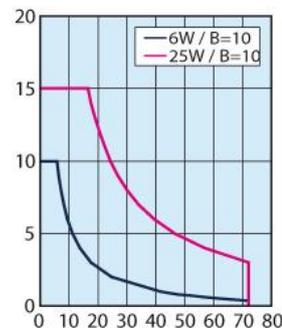
Gearhead reduction ratio

Belt speed (m / min) as a function of the frequency and the selected gearhead reduction ratio

	Belt speed	
	50 Hz	60 Hz
5	60.0	72.0
7.5	40.0	48.0
9	33.3	40.0
12.5	24.0	28.8
15	20.0	24.0
18	16.7	20.0
25	12.0	14.4
30	10.0	12.0
36	8.3	10.0
50	6.0	7.2
60	5.0	6.0
75	4.0	4.8
90	3.3	4.0
100	3.0	3.6
120	2.5	3.0
150	2.0	2.4
180	1.7	2.0

Further information

- Connection ▶ from page 43
- Belt characteristics ▶ from page 36
- Accessories ▶ from page 63

Further information

- Connection ▶ from page 43
- Belt characteristics ▶ from page 36
- Accessories ▶ from page 63

4.3.39 CVGTBE

Special features

- Timing belt conveyors, double track
- Pulley Ø 50 mm
- Head drive
- Stoppers, sensors can be installed in the gap

Technical data

Belt Width (mm) *	80~300	
Length (mm)*	265~3000	
Weight (kg)*	9.1~24.3	
Power output (W)*	25	40
Voltage (V)	230	
Frequency (Hz)	50	

* Specifications depend on the design of the conveyor

Conveyor Capacity

Permissible transfer mass (vertically in kg) as a function of belt speed (horizontal in m / min) and selected transmission ratio

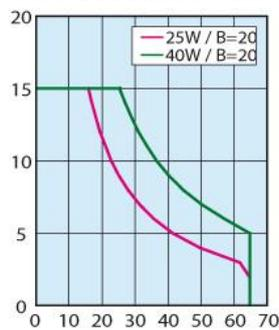
Gearhead reduction ratio

Belt speed (m / min) as a function of the frequency and the selected gearhead reduction ratio

	Belt speed	
	50 Hz	60 Hz
5	54.0	64.8
7.5	36.0	43.2
9	30.0	36.0
12.5	21.6	25.9
15	18.0	21.6
18	15.0	18.0
25	10.8	13.0
30	9.0	10.8
36	7.5	9.0
50	5.4	6.5
60	4.5	5.4
75	3.6	4.3
90	3.0	3.6
100	2.7	3.2
120	2.3	2.7
150	1.8	2.2
180	1.5	1.8

4.3.40 CVGTNE

Special features

- Timing belt conveyors, double track
- Pulley Ø 30 mm
- Central drive
- Stoppers, sensors can be installed in the gap

Technical data

Belt Width (mm) *	80~300	
Length (mm)*	265~3000	
Weight (kg)*	6.6~13.4	
Power output (W)*	6	25
Voltage (V)	230	
Frequency (Hz)	50	

* Specifications depend on the design of the conveyor

Conveyor Capacity

Permissible transfer mass (vertically in kg) as a function of belt speed (horizontal in m / min) and selected transmission ratio

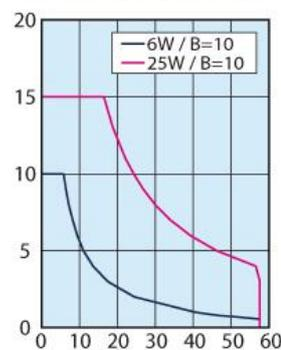
Gearhead reduction ratio

Belt speed (m / min) as a function of the frequency and the selected gearhead reduction ratio

	Belt speed	
	50 Hz	60 Hz
5	48.0	57.6
7.5	32.0	38.4
9	26.7	32.0
12.5	19.2	23.0
15	16.0	19.2
18	13.3	16.0
25	9.6	11.5
30	8.0	9.6
36	6.7	8.0
50	4.8	5.8
60	4.0	4.8
75	3.2	3.8
90	2.7	3.2
100	2.4	2.9
120	2.0	2.4
150	1.6	1.9
180	1.3	1.6

Further information

- Connection ▶ from page 43
- Belt characteristics ▶ from page 36
- Accessories ▶ from page 63

Further information

- Connection ▶ from page 43
- Belt characteristics ▶ from page 36
- Accessories ▶ from page 63

4.3.41 CVGTPE

Special features

- Timing belt conveyor, double track
- Pulley Ø 50 mm
- Central drive
- Stoppers, sensors can be installed in the gap

Technical data

Belt Width (mm) *	80~300	
Length (mm)*	325~3000	
Weight (kg)*	9.8~26.4	
Power output (W)*	25	40
Voltage (V)	230	
Frequency (Hz)	50	

* Specifications depend on the design of the conveyor

Conveyor Capacity

Permissible transfer mass (vertically in kg) as a function of belt speed (horizontal in m / min) and selected transmission ratio

Gearhead reduction ratio

Belt speed (m / min) as a function of the frequency and the selected gearhead reduction ratio

	Belt speed	
	50 Hz	60 Hz
5	48.0	57.6
7.5	32.0	38.4
9	26.7	32.0
12.5	19.2	23.0
15	16.0	19.2
18	13.3	16.0
25	9.6	11.5
30	8.0	9.6
36	6.7	8.0
50	4.8	5.8
60	4.0	4.8
75	3.2	3.8
90	2.7	3.2
100	2.4	2.9
120	2.0	2.4
150	1.6	1.9
180	1.3	1.6

Further information

- Connection ▶ from page 43
- Belt characteristics ▶ from page 36
- Accessories ▶ from page 63

4.3.42 CVSPAЕ

Special features

- Plastic chain conveyors, double track
- Sprocket-wheel Ø 57 mm
- Head drive
- Stoppers, sensors can be installed in the gap

Technical data

Belt Width (mm) *	80~300	
Length (mm)*	300~3000	
Weight (kg)*	9.6~27.7	
Power output (W)*	25	40
Voltage (V)	230	
Frequency (Hz)	50	

* Specifications depend on the design of the conveyor

Conveyor Capacity

Permissible transfer mass (vertically in kg) as a function of belt speed (horizontal in m / min) and selected transmission ratio

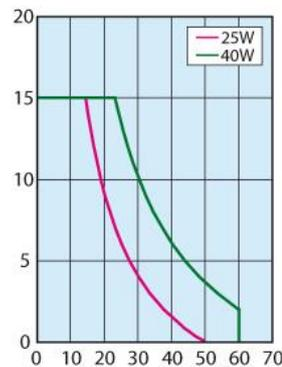
Gearhead reduction ratio

Belt speed (m / min) as a function of the frequency and the selected gearhead reduction ratio

	Belt speed	
	50 Hz	60 Hz
5	53.7	64.4
7.5	35.8	43.0
9	29.8	35.8
12.5	21.5	25.8
15	17.9	21.5
18	14.9	17.9
25	10.7	12.9
30	9.0	10.7
36	7.5	9.0
50	5.4	6.4
60	4.5	5.4
75	3.6	4.3
90	3.0	3.6
100	2.7	3.2
120	2.2	2.7
150	1.8	2.1
180	1.5	1.8

Further information

- Connection ▶ from page 43
- Belt characteristics ▶ from page 36
- Accessories ▶ from page 63

4.3.43 CVSSAE

Special features

- Stainless steel belt conveyors, single belt
- Pulley \varnothing 50 mm
- Head drive
- Heat resistance and conductivity

Technical data

Belt Width (mm) *	40~150		
Length (mm)*	250~2000		
Weight (kg)*	6.7~20.4		
Power output (W)*	6	25	40
Voltage (V)	230		
Frequency (Hz)	50		

* Specifications depend on the design of the conveyor

Conveyor Capacity

Permissible transfer mass (vertically in kg) as a function of belt speed (horizontal in m / min) and selected transmission ratio

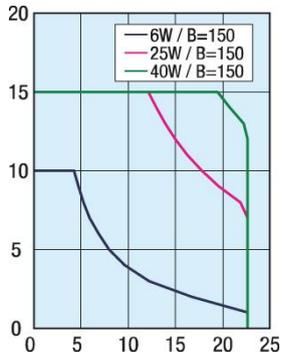
Gearhead reduction ratio

Belt speed (m / min) as a function of the frequency and the selected gearhead reduction ratio

	Belt speed	
	50 Hz	60 Hz
12.5	18.8	22.6
15	15.7	18.8
18	13.1	15.7
25	9.4	11.3
30	7.9	9.4
36	6.5	7.9
50	4.7	5.7
60	3.9	4.7
75	3.1	3.8
90	2.6	3.1
100	2.4	2.8
120	2.0	2.4
150	1.6	1.9
180	1.3	1.6

4.3.44 CVDSAE

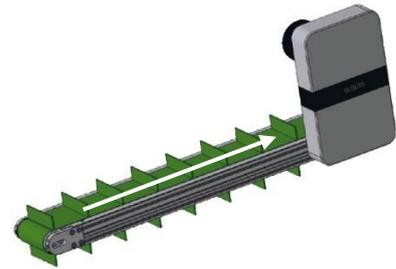
Special features

- Flat belt conveyor with studs, single belt
- Pulley \varnothing 50 mm
- Head drive
- Suitable for foodstuffs, sloped design

Technical data

Belt Width (mm) *	50~300
Length (mm)*	500~3000
Weight (kg)*	11.4~37.8
Power output (W)*	40
Voltage (V)	230
Frequency (Hz)	50

* Specifications depend on the design of the conveyor

Conveyor Capacity

Permissible transfer mass (vertically in kg) as a function of belt speed (horizontal in m / min) and selected transmission ratio

Gearhead reduction ratio

Belt speed (m / min) as a function of the frequency and the selected gearhead reduction ratio

	Belt speed	
	50 Hz	60 Hz
7.5	31.4	37.7
9	26.2	31.4
12.5	18.8	22.6
15	15.7	18.8
18	13.1	15.7
25	9.4	11.3
30	7.9	9.4
36	6.5	7.9
50	4.7	5.7
60	3.9	4.7
75	3.1	3.8
90	2.6	3.1
100	2.4	2.8
120	2.0	2.4
150	1.6	1.9
180	1.3	1.6



Further information

- Connection ▶ from page 43
- Belt characteristics ▶ from page 36
- Accessories ▶ from page 63

Further information

- Connection ▶ from page 43
- Belt characteristics ▶ from page 36
- Accessories ▶ from page 63

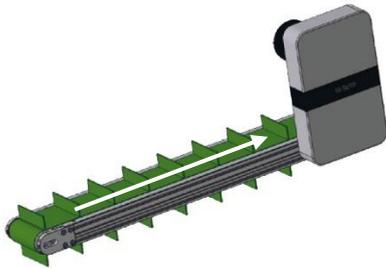
4.3.45 CVDSBE

Special features

- Flat belt conveyor with studs, single belt
- Pulley Ø 50 mm
- Head drive
- Suitable for foodstuffs, sloped design, oil resistant

Technical data

Belt Width (mm) *	50~300
Length (mm)*	500~3000
Weight (kg)*	11.4~37.8
Power output (W)*	40
Voltage (V)	230
Frequency (Hz)	50

* Specifications depend on the design of the conveyor

Conveyor Capacity

Permissible transfer mass (vertically in kg) as a function of belt speed (horizontal in m / min) and selected transmission ratio

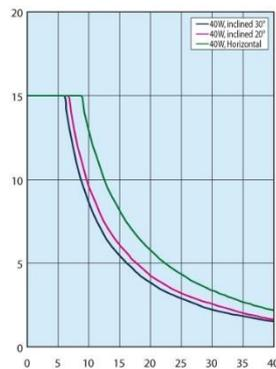
Gearhead reduction ratio

Belt speed (m / min) as a function of the frequency and the selected gearhead reduction ratio

	Belt speed	
	50 Hz	60 Hz
7.5	31.4	37.7
9	26.2	31.4
12.5	18.8	22.6
15	15.7	18.8
18	13.1	15.7
25	9.4	11.3
30	7.9	9.4
36	6.5	7.9
50	4.7	5.7
60	3.9	4.7
75	3.1	3.8
90	2.6	3.1
100	2.4	2.8
120	2.0	2.4
150	1.6	1.9
180	1.3	1.6

Further information

- Connection ▶ from page 43
- Belt characteristics ▶ from page 36
- Accessories ▶ from page 63

4.3.46 CVSPCE

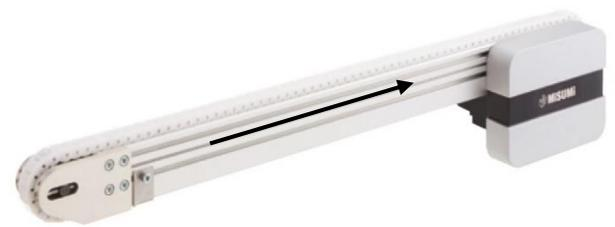
Special features

- Plastic chain conveyors, single belt
- Chain-wheel Ø 57 mm
- Head drive
- Prevents scratches, easy to maintain

Technical data

Belt Width (mm) *	20	
Length (mm)*	350~3000	
Weight (kg)*	5.3~12.9	
Power output (W)*	6	25
Voltage (V)	230	
Frequency (Hz)	50	

* Specifications depend on the design of the conveyor

Conveyor Capacity

Permissible transfer mass (vertically in kg) as a function of belt speed (horizontal in m / min) and selected transmission ratio

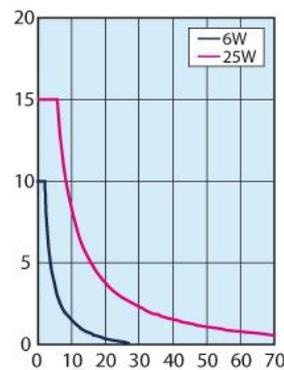
Gearhead reduction ratio

Belt speed (m / min) as a function of the frequency and the selected gearhead reduction ratio

	Belt speed	
	50 Hz	60 Hz
5	53.7	64.4
7.5	35.8	43.0
9	29.8	35.8
12.5	21.5	25.8
15	17.9	21.5
18	14.9	17.9
25	10.7	12.9
30	9.0	10.7
36	7.5	9.0
50	5.4	6.4
60	4.5	5.4
75	3.6	4.3
90	3.0	3.6
100	2.7	3.2
120	2.2	2.7
150	1.8	2.1
180	1.5	1.8

Further information

- Connection ▶ from page 43
- Belt characteristics ▶ from page 36
- Accessories ▶ from page 63

4.4 Belts Overview

The conveyor systems are designed with different belts depending on the configuration, operating conditions, and conveyed materials. The width and length can be freely selected. The following belts are available depending on the application:

Belt	Application	Illustration
Belt	<ul style="list-style-type: none"> ■ all-purpose ■ sliding ■ for electronic components ■ oil-resistant ■ thin fluid 	
Flat belts with guide	<ul style="list-style-type: none"> ■ smooth operation 	
Stainless steel belt	<ul style="list-style-type: none"> ■ all-purpose ■ sliding 	
Timing belts	<ul style="list-style-type: none"> ■ transport of work-piece holders 	
Plastic chain	<ul style="list-style-type: none"> ■ transport of work-piece holders 	
Flat belt conveyor with studs	<ul style="list-style-type: none"> ■ Transport of food-stuffs 	



Belt ordering - additional information

Detailed information on technical specifications and operational areas of the belts, as well as order options can be found in the catalogue or on our website www.misumi-europe.com.

CAUTION



Damage to the conveyor belt

Improper or inappropriate use of the conveyor belt can lead to a shortened life span and poor conveyor quality.

Belts with a thickness of 0.1 and 0.15 mm are not suitable for conveyor systems!

Avoid vertical impacts to the belt, because the belt is very thin. If the belt is buckled, its life span is shortened.

Workpieces that do not directly touch the belt must be loaded with chutes or other mechanical handling equipment. Ensure that conveyed materials that come into contact with the belt have a lower surface hardness than the belt.

Do not use belts where dust has penetrated below the belt plate or guide!

Use designated pulleys and guidance rollers!

4.4.1 Technical Data - Belt

Belt characteristics - timing belts

MISUMI part numbers	Material	Allowable Tension (N)	Continuous use Temperature °C	Weight g/m (width 10 mm)
LTBR	Polyurethane	120	-20~70	32.5
LTBRA	Polyurethane	150	0~80	20.8
LBTJA	Polyurethane	150	0~80	20.8

Belt characteristics - plastic chain

MISUMI part numbers	Material	Allowable Tension (N)	Continuous use Temperature °C	Reference mass (kg/m)
CHEED	Polyacetal	45	-5~65	0.32

Permissible chain speed (m/min)	Sliding friction coefficient f1
60	0.32

Belt characteristics - flat belts

MISUMI part numbers	Application	Material front side	Material reverse side	Colour	Thickness mm	Weight kg/m ²	Permissible tension N/m	min. pulley diameter Ø mm	Cutting edge	Continuous use Temperature °C	Friction coefficient (with polished steel)	
											Front side	Back side
HBLT	All-purpose operation	Polyurethane		green	0.8	0.9	4	25	R8	-10~80	0.3	0.1
HBLTWH				white								
HBLTG				green	0.8	0.7	4	15	R3	-30~80	0.8	0.2
HBLTGDN				green	1.7	1.9	8	50	—	-30~100	0.6	0.2
HBLBN				sky blue	1.4	1.3	3	15	R3			
HBLYGN				yellow		1.5	8	25(15) ^{*1}	(R3) ^{*1}			
SHBLTG	Accumulation mode	PU impregnated	Polyester	green	0.5	0.5	4	25	R3	-10~80	0.15	0.1
SHBLT		Polyester		white							0.1	0.1
LHBLT	For inclined transport	flexible polyurethane	Polyester	green	1.5	1.6	4	30	—	-10~80	1.7	0.1
LHBLTWH				white	0.9	1	3.5	25				0.15
GBLG	Grip specifications	Polyurethane		green	1	0.9	4	15	R3	-30~100	0.7	0.2
GBLW				white								
GBLGSN				green	1.6	1.6	8	25	—			
OHBLTG	Oil-Resistant	Oil-resistant polyurethane		green	0.8	0.7	4	15	R3	-30~80	0.8	0.2
OHBLTGN				green	1.4	1.5	8	25	R3		0.8	0.2
OHBLTW		Polyurethane		white	0.8	0.7	4	15	R3	-30~80	0.6	0.2
OHBLGN				white	1.4	1.5	8	25(15) ^{*1}	(R3) ^{*1}	0.6	0.2	
NSHBLT	Smooth operation	Polyurethane	Polyester	white	0.9	1	3.5	25	R5	-10~80	0.2	0.15
NSHBLTS				white	0.8	0.7	4	15	R3	-10~80	0.6	0.2
NSHB				sky-blue	0.8	0.7	4	15	R3	-30~100	0.6	0.2
NSHBLTG				lime-	0.8	0.7	4	15	R3	-30~100	0.6	0.2
NSHBWN				white	1.4	1.5	8	25(15) ^{*1}	(R3) ^{*1}	-30~100	0.6	0.2
NSHBN				sky-blue	1.4	1.5	8	25(15) ^{*1}	(R3) ^{*1}	-30~100	0.6	0.2
NSHBLGN				lime-	1.4	1.5	8	25(15) ^{*1}	(R3) ^{*1}	-30~100	0.6	0.2
NFHBG				green	0.8	0.7	4	15	R3	-30~100	0.4	0.2
NFHBW				white	0.8	0.7	4	15	R3	-30~100	0.4	0.2
NFHBGN				green	1.4	1.4	8	30(15) ^{*1}	(R3) ^{*1}	-30~100	0.4	0.2
NFHBWN				white	1.4	1.4	8	30(15) ^{*1}	(R3) ^{*1}	-30~100	0.4	0.2
BHFHBWN				white	1.4	1.5	8	30(15) ^{*1}	(R3) ^{*1}	-30~100	0.4	0.2

MISUMI part numbers	Application	Material front side	Material reverse side	Colour	Thickness mm	Weight kg/m ²	Permissible tension N/m	min. pulley diameter Ø mm	Cutting edge	Continuous use Temperature °C	Friction coefficient (with polished steel)	
											Front side	Back side
FHBLT	For food transport	Polyurethane	Polyester	white	0.8	0.9	3.5	20	R3	-10~80	0.2	0.15
KBLW				white	0.8	0.7	4	15	R3	-30~100	0.6	0.2
KBLT				sky-blue	0.8	0.7	4	15	R3	-30~100	0.6	0.2
KBLWSN				white	1.4	1.5	8	25(15) ^{*1}	(R3) ^{*1}	-30~100	0.6	0.2
KBLWDN				white	1.7	1.9	8	50	-	-30~100	0.6	0.2
PHBLB				white	1.3	1	4	20	-	-30~100	0.6	0.2
PHBLBN				sky-blue	1.7	1.6	3	30	-	-30~100	0.6	0.2
PHBLWN				white	1.7	1.6	3	30	-	-30~100	0.6	0.2
DHBLT	Conveyors for electronic components	electrically conductive polyurethane	Polyester	black	0.6	0.7	3	25	R3	-10~80	0.2	0.1
DHBLTS				black	0.8	0.7	4	15	R3	-10~80	0.8	0.2
DHBLGN		Polyurethane	black	1.4	1.5	8	25(15) ^{*1}	(R3) ^{*1}	-30~80	0.6	0.2	

Characteristics belt - belts with guides

MISUMI part numbers	Application	Material front side	Material reverse side	Colour	Thickness mm	Weight kg/m ²	Permissible tension N/m	min. pulley diameter Ø mm	Cutting edge	Continuous use Temperature °C	Friction coefficient (with polished steel)
HBLTDSG	All-purpose operation	Polyurethane	Polyester	green	0.8	0.7	4	15	-30~80	0.8	0.2
HBLTDSW				white							
SHBLTDSG	Accumulation mode	PU impregnated		green	0.6	0.4	4	20	-30~80	0.2	0.2
SHBLTDSW		Polyester		white						0.2	0.2
GBLDSG	Grip specifications	Polyurethane		green	1.0	0.9	4	15	-30~100	0.7	0.2
GBLDSW				white	1.0	0.9	4	15	-30~100	0.7	0.2
OHBLTDSG	oil-resistant	Oil-resistant Polyurethane		green	0.8	0.7	4	15	-30~80	0.8	0.2
OHBLTDSW		Polyurethane		white	0.8	0.7	4	15	-30~80	0.8	0.2
NSHBLTDS	smooth operation	Polyurethane		white	0.8	0.7	4	15	-30~80	0.9	0.2
NSHDSB				sky-blue	0.8	0.7	4	15	-30~100	0.6	0.2
NSHBLGDS				lime-green	0.8	0.7	4	15	-30~100	0.6	0.2
HFHBD SG				green	0.8	0.7	4	15	-30~100	0.4	0.2
HFHBD SW				white	0.8	0.7	4	15	-30~100	0.4	0.2
KBLDSW	For food transport	Polyurethane		white	0.8	0.7	4	15	-30~100	0.6	0.2
KBLTDSG				sky-blue	0.8	0.7	4	15	-30~100	0.6	0.2
PHBLDSB				sky-blue	1.3	1	4	20	-30~100	0.6	0.2
DHBLTDS	Conveyors for electronic components	electrically conductive polyurethane		black	0.8	0.7	4	15	-30~80	0.8	0.2

Characteristics belt –flat belt with studs

MISUMI part numbers	Application	Material front side	Material reverse side	Colour	Thickness mm	Weight kg/m ²	Permissible voltage kg/cm	min. Pulley diameter Ø mm	Continuous use Temperature °C	Food stuff possible	Friction coefficient (with polished steel)		Rib hardness Shore A (°)
											Front side	Back side	
YBLTG	Flat belt with studs	Polyurethane	Polyester	green	1.3	1.5	4.6	50	-15~80	no	-	-	70
YBLTW				white	1.2	1.3	6		-30~80	yes			

Belt characteristics - stainless steel belt

MISUMI part numbers	Thickness mm	Weight kg/m ²	Permissible voltage kg/cm	min. Pulley diameter Ø mm	Continuous use Temperature °C	Electrical resistance of the surface Ω	Friction coefficient (with polished steel)	Hardness HV	Young's modulus of elasticity kg/mm ²	Thermal expansion coefficient x 10 ⁻⁶ /C°
STHBLT	0.1	0.8	4	50	-80~110	0.2	0.2	370 or more	19700	17.3
	0.15	1.2	6	75	-80~120	0.3	0.2			
	0.2	1.6	8	100	-80~130	0.5	0.2			

4.4.2 Exchanging the Belts/Plastic Chains

The following criteria must be taken into account when exchanging a belt or a plastic chain.

Minimum permissible belt pulley diameter	Heed the specified minimum belt pulley diameter for MISUMI belts (bend radius).
Belt and plastic chain lengths	Calculate and compare the length of the belt /plastic chain based on the table below.
Conveying direction	Note that for some belts, the conveying direction is fixed.

4.4.2.1 Formula List for Calculating the Belt Length

Part number	Belt type	Number of Tracks	Drive position	Belt pulley \varnothing	Formula	Unit
SVKAE	Flat belt	Single track	Head	30	$(2L+97)/1.002/1000$	m [*2]
SVKBE	Flat belt (with meandering prevention)			30	$(2L+97)/1.002/1000$	m [*2]
SVKNE	Flat belt	Single track	Centre	30	$(2L+270)/1.002/1000$ [*6]	m [*2]
SVKRE	Flat belt (with meandering prevention)			30	$(2L+270)/1.002/1000$ [*6]	m [*2]
GVHAE	Flat belt	Single track	Head	30	$(2L+98)/1000$	m [*2]
GVFAE	Flat belt	Single track	Head	30	$(2L+98)/1000$	m [*2]
GVHNE	Flat belt	Single track	Centre	30	$(2L+250)/1000$	m [*2]
GVFNE	Flat belt	Single track	Centre	30	$(2L+250)/1000$	m [*2]
GV TSAE	Synchronous belt	Single track	Head	30	$(2L+220)/5$	Teeth
GV TSNE	Synchronous belt	Single track	Centre	30	$(2L+240)/5$	Teeth
GVTWAUE	Synchronous belt (INSIDE the motor)	Double track	Head	30	Drive side: $(2L+220)/5$ [*7] Driven side: $(2L+100)/5$ [*7]	Teeth
GVTWASE	Synchronous belt (OUTSIDE the motor)	Double track	Head	30	Drive side: $(2L+220)/5$ [*7] Driven side: $(2L+100)/5$ [*7]	Teeth
GVTWNUE	Synchronous belt (INSIDE the motor)	Double track	Centre	30	Drive side: $(2L+240)/5$ [*7] Driven side: $(2L+100)/5$ [*7]	Teeth
GVTWNSE	Synchronous belt (OUTSIDE the motor)	Double track	Centre	30	Drive side: $(2L+240)/5$ [*7] Driven side: $(2L+100)/5$ [*7]	Teeth
CVGAE	Flat belt	Single track	Head	30	$(2L+94)/1000$	m [*2]
CVGCE				50	$(2L+160)/1000$	m [*2]
CVGNE	Flat belt	Single track	Centre	30	$(2L+A)/1000$ [*6]	m [*2]
CVGRE				50	$(2L+A)/1000$ [*6]	m [*2]
CVGBE	Flat belt (with meandering prevention)	Single track	Head	30	$(2L+94)/1000$	m [*2]
CVGDE				50	$(2L+160)/1000$	m [*2]
CVGPE	Flat belt (with meandering prevention)	Single track	Centre	30	$(2L+A)/1000$ [*6]	m [*2]
CVGWE				50	$(2L+A)/1000$ [*6]	m [*2]
CVSEE	Flat belt	Single track	Head	60/30	$(2L+161)/1.002/1000$	m [*2]
CVSFE	Flat belt (with meandering prevention)			60/30	$(2L+161)/1.002/1000$	m [*2]
CVSXE	Flat belt	Single track	Centre	30	$(2L+284)/1.002/1000$	m [*2]
CVSYE	Flat belt (with meandering prevention)			30	$(2L+284)/1.002/1000$	m [*2]
CVSSAE	Stainless steel belt	Single track	Head	50	$(2L+160)/1000$	m [*2]
CVSFAE	Flat belt	Single track	Head	30	$(2L+97)/1.002/1000$	m [*2]
CVSFBE				50	$(2L+160)/1.002/1000$	m [*2]
CVSFCE	Flat belt (with meandering prevention)	Single track	Head	30	$(2L+97)/1.002/1000$	m [*2]
CVSFDE				50	$(2L+160)/1.002/1000$	m [*2]
CVSJAE	Flat belt (with meandering prevention)	Single track	Centre	30	$(2L+262)/1.002/1000$	m [*2]
CVSTCE	Synchronous belt	Single track	Head	19/20	CVSTC10: $(2L+130)/5$ CVSTC20: $(2L+165)/5$	Teeth
CVSTRE	Synchronous belt	Single track	Centre	19/20	CVSTR10: $(2L+215)/5$ CVSTR20: $(2L+240)/5$	Teeth
CVSMAE	Flat belt	Single track	Integrated	70	$(2L+220)/1.002/1000$	m [*2]
CVSTAE	Synchronous belt	Double track	Head	30	$(2L+100)/5$	Teeth [*3]
CVSTBE				50	$(2L+180)/10$	Teeth [*4]
CVSTNE	Synchronous belt	Double track	Centre	30	$(2L+260)/5$	Teeth [*3]
CVSTPE				50	$(2L+420)/10$	Teeth [*5]
CVSPA E	Plastic chain	Double track	Head	57 [*1]	$(2L+179)/12.7$	Connections [*4]
CVDSA E	Flat belt with studs	Single track	Head	50	$(2L+160)/1000$	m [*2]

Part Number	Belt Type	Number of Tracks	Drive Position	Belt Pulley Ø	Formula	Unit
CVDSBE	Flat belt with studs	Single track	Head	50	$(2L+160)/1000$	m [*2]
CVLP AE	Flat belt	Single track	Centre	15	$(2L+223)/1000$	m [*2]
CVSPCE	Plastic chain	Single track	Head	57 [*1]	$(2L+179)/12.7$	Connections [*4]
CVMAE	Flat belt	Single track	Head	30	$(2L+94)/1000$	m [*2]
CVMBE	Flat belt (with meandering prevention)	Single track	Head	30	$(2L+94)/1000$	m [*2]

[*1] The sprocket pitch diameter applies for plastic chains

[*2] Round down to the 2nd decimal place.

[*3] Round to a whole number

[*4] Round to a whole number

[*5] Round up to a whole number

[*6] For the knife edge or roller edge option, refer to the following table A $[(2L+A)/1.002/1000]$

[*7] As shown below, double track timing belt conveyors contain two belts with different amount of teeth. One for the drive part, and the other for the driven part.

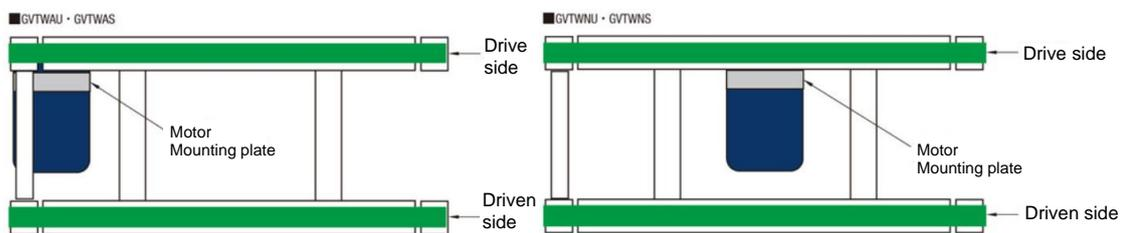

		SVKNE	SVKRE	CVGNE	CVGPE	CVGRE	CVGWE
	Standard design*	270	270	270	270	330	330
HR	Knife edge on both sides	257	257	250	250	300	300
MR	Roller edge on one side						
WR	Roller edge on both sides	244	244	240	240	260	260

* without specification of a design variant

4.5 Components – Electrical system/Control



Note

The chapter „Components – Electrical system/Control“ relates solely to conveyor systems that are delivered with drive motor! Conveyor systems without drive motor are classed as incomplete machines for the purposes of the Machinery Directive 2006/42/EC!

Various electrical components are installed as operating equipment or safety components on the conveyor system (complete).

Electrical components are marked with the following warning symbols:



"Dangerous electrical voltage"

DANGER



Danger of electric shock from faulty electrical components, contact with live parts, human error and lack of qualifications



There are hazards from electric energy and residual energy. Live current remains in cables, components and equipment for about 5 minutes after the machine is turned off.



Live parts may be freely accessible in the switch box and at connection points of the electrical components!



Prior to operation, disconnect the conveyor system from the power supply and ensure that it is secured against accidental and unauthorised re-start!

Only allow trained personnel to work on the electrical supply or accessible live components!

Non-compliance (e.g. freely accessible contacts, incorrect placement of the ground conductor, etc.) can lead to electric shock and, as a result, to serious injury or death!

4.5.1 Drive motor

Depending on the configuration, the conveyor systems are designed with one of the following drive motors.

Make	Power [W]	Specification	Voltage [V]
Panasonic	6, 25, 40, 60, 90	Induction motor	1-phase 230 V
Oriental	6, 25, 40, 60, 90	Induction or variable speed motor	1-phase 230 V

4.5.2 Electric Speed Controller

Depending on the motor configuration, the conveyor systems are designed with speed regulators with a power switch.

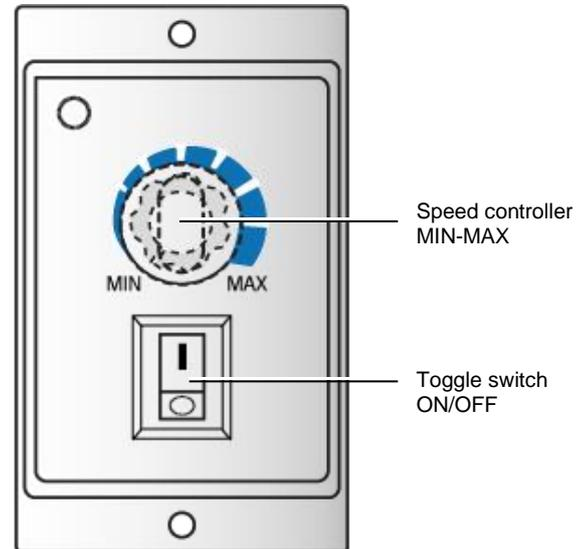

Drive motor speed controller for installation (example)



Electrical connections

The assignment of the terminals on the back of the speed controller can be found in the wiring diagrams in the chapter "Wiring Diagram" page 47.

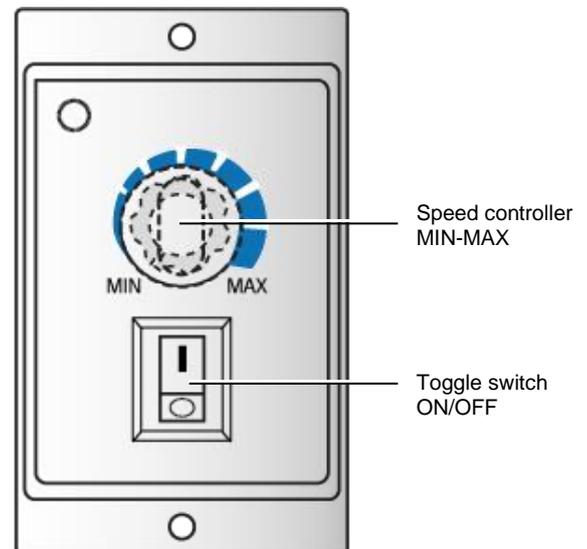

Drive motor speed controller (rail mounting)

4.6 Safety Coverings

Dangerous zones of the machine are secured by fixed guards. Optionally, the belt routing can be secured by transparent plastic covers.

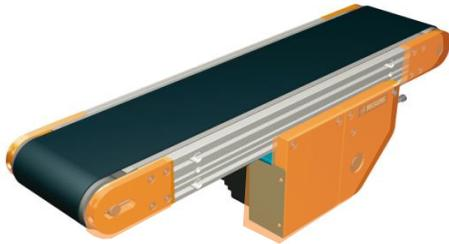

Fixed motor guards, rollers (example)

DANGER





Risk of failure to observe the danger zones

There are dangers posed by electrical, mechanical, and thermal energies, as well as special residual dangers.

Make sure that no one remains in the danger zone of the machine when disassembling the protective cover during the set-up operation or when changing the belts.

4.7 Frequently Asked Questions (FAQ)

Can the direction of the conveyor be reversed?

Reversing the direction of rotation is not recommended.

The conveyor capacity is insufficient due to changes to workpiece loads. Solutions?

Consider changing the motor or transmission. A replacement of the gearbox is recommended because modifications to the mounting plate are required as a result of motor modifications. A replacement of the motor results in a change of the external dimensions, whereby a modification of the mounting plate by the user is required. Please note that the belt speed drops if the transport capacity is increased by replacing the gearhead.

Can the speed of the induction motor be changed?

The speed of the induction motor can not be changed. The conveyor speed can be changed by replacing the gearheads. The gearheads are available through MISUMI.

What is the expected service life of the motor?

For daily use in conveyors of 8 hours with constant loads, the standard life expectancy is 10,000 hours. This is a reference value only, as the actual life expectancy depends on the conditions of use.

Can it be run periodically (on and off)?

The motor used is designed for continuous operation, and frequent switching on and off is not recommended. However, it can be run periodically with intervals of at least 10 seconds.

Explanations for conveyor capacity diagram?

First check the workpiece load and compare it. Choose a point with the conveyor belt load and speed in the diagram, and make sure that the point is not over the power limit of the installed motors. In the example, a conveyor load of 8 kg/unit and a belt speed of 5 m/min indicates that a 25W motor can be used.

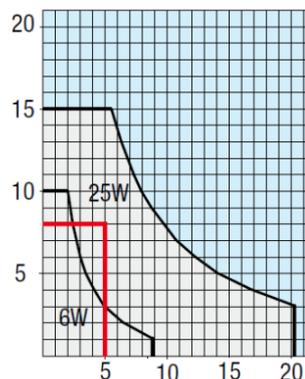

5. Transportation, Installation, Connection



Safety Instructions

Follow safety instructions in Chapter 3, "Safety Instructions".

In addition, all safety instructions and signs on the conveyor system and in the manufacturer's documentation in the appendix must be heeded.

5.1 Transport

Depending on the configuration and dimensions, the conveyor systems are packaged (cardboard or wooden box) and delivered by truck.

Pallets are used for transport. These are moved by forklift.

- Ensure that loads that are dismantled or installed, and whose weight cannot be carried, are secured with appropriate equipment (ropes or hoists)!
- Check by means of visual inspection whether load-securing devices are free of damage and in good condition. Only lift the cargo at the designated points!
- Check the delivery for completeness, damage, and for any other noticeable issues!
- Respect all valid national safety and accident prevention regulations!
- For questions regarding transport, set-up or installation of the machine contact MISUMI Europa GmbH.
- Make sure that there are no loose parts on the machine that could fall off during transport!
- Only allow authorised personnel to connect / disconnect (reconnect/disconnect) the energy supply (electricity)!
- Only use lifting gear that is functional and in technically perfect condition with sufficient load-bearing capacity for transporting loads. Make sure that the load-bearing capacity of the lifting gear, the load-bearing equipment and the means of transport correspond to the specified loads for the machine!



*Delivery Condition

The conveyor systems are delivered in sections based on their frame length, in accordance with the order.

Length ≤ 2000	One-piece frame
Length ≥ 2005	Frame divided into 3 sections

DANGER



Danger from falling loads

Dangers during transport arise due to human error and insufficient or incorrectly secured loads.



For in-plant transportation, a forklift or other industrial machines with sufficient capacity and adequate fork length must be used.



Place a non-slip rubber mat on the forks to prevent the machine from slipping. Mind the centre of gravity during transport. Secure machine on the truck bed with suitable means when transporting via truck.



Walking under suspended loads is prohibited

Wear protective equipment!

5.2 Installation

- The installation location must have electrical power.
- The circuit breakers must be easily accessible.



Floor plan and drawings

More detailed information about the dimensions and weight of the machine components can be found in the plans and drawings in the appendix of this manual!

5.2.1 Unpacking and Installation

The location provided for the machine must be stable and level.

Suggestion: level cement floor permissible for machine halls

- Carefully unpack the conveyor system. Remove the protective packaging and any transport safety devices. Properly dispose of packaging materials!
- Pay attention to the exact dimensions of your custom-configured conveyor system!
- Place the conveyor system so that a work and/or service area (excluding storage area) of at least 800 mm is guaranteed in all directions!
- Observe the required loading capacity of the foundation of at least 3 t/m²!

WARNING

Danger from disregarding the danger zone, working area and service area!

Disregarding the safety distance to the conveyor system can cause hazards from electrical, mechanical and thermal energies as well as specific residual risks.

Ensure a safety distance of 800 mm to the conveyor system!

Do not set down or store any objects in the working or service area!

Ensure free access to the machine for maintenance and inspection is always available!

The appropriate security clearance to the machinery – especially during set-up and normal operation – must be maintained!

5.2.2 Alignment of the Conveyor System

For the alignment of the mounted machine elements you need tools such as a fitting tool kit and a level.

Depending on the customer configuration, the conveyor systems are designed with either movable casters or adjustable screws.

- Roughly line up the conveyor system adjacent to linked machines!
- Align the machine only by means of the height-adjustable machine feet (bases)!
- Check the horizontal position of all components with a level!
- Then fix the movable casters or adjustable screws against movement and slippage!
- If necessary, screw the machine feet to the shop floor!

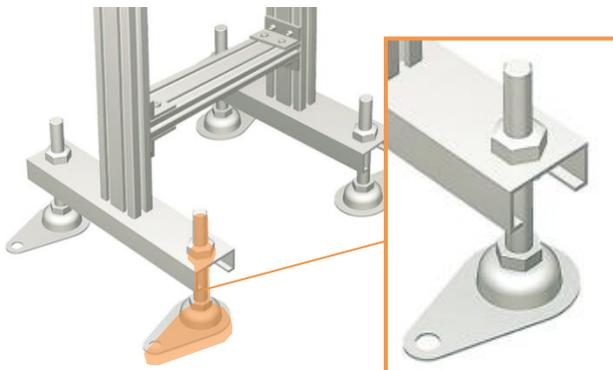

Example screws

5.3 Operating conditions

Property	Physical conditions
Environmental temperature	<ul style="list-style-type: none"> ■ +5°C to +45°C (heated hall) (Refer to operating temperatures of the belts)
Operating temperature	<ul style="list-style-type: none"> ■ -10°C~40°C
Humidity	<ul style="list-style-type: none"> ■ 30% to 60%
Installation height	<ul style="list-style-type: none"> ■ up to 1000 m above sea level (NN)
Explosive atmosphere	<ul style="list-style-type: none"> ■ Use in explosive atmospheres is prohibited
Contamination	<ul style="list-style-type: none"> ■ No high contamination from oil, water, dust, acids or corrosive gases
Other	<ul style="list-style-type: none"> ■ No direct sunlight ■ Sufficient lighting, 250Lx (German workplace regulation §7) ■ If the workroom is insufficiently illuminated, the machine must be provided with additional workspace lighting ■ Sufficient ventilation of the workroom (stress on the operator) ■ Machine has no explosion protection

5.4 Connection

Note

The chapter "Connection" relates solely to conveyor systems that are delivered with drive motor! Conveyor systems without drive motor are classed as incomplete machines for the purposes of the Machinery Directive 2006/42/EC!

Heed the instructions for connection of third-party drives given in chapter 5.6, page 49!

Once the machine is set up, allow the electrical, control-related equipment to be connected by qualified personnel.

WARNING

Risk of injury from unexpected start

During connection of the equipment, there is a danger that the machine starts up unexpectedly or makes other unexpected movements.



Secure the machine against accidental activation during the installation!



Wear protective equipment!

Verify that no unauthorised persons have access to the machine during the installation. Prohibit third-party access to the work and service area!

- Route connecting cables to the conveyor system tension-free, so that no hazardous points result!
- Only allow skilled personnel who are familiar with the local electrical connection and safety regulations to connect the wiring according to the connection diagrams for the electric supply!

5.4.1 Connection Location of the Machine

An electrical connection is required for the operation of the conveyor system. The manufacturer prepares the interfaces on the machine accordingly.

If the manufacturer did not install the electric facilities, the electrical installation must be performed by qualified personnel of the operating company. The wiring diagram is inside the terminal box or in the attached wiring diagrams for the motor.

Attention

Make sure that the supplied voltage specified at the electrical connection is in accordance with the indicated supply voltage on the machine. The rating is stated in the technical specifications in chapter 4.1.

The return current to the ground wire and grounding connection cables must have the same cross-section.

The speed controller "Oriental" is mounted in housings.

DANGER



Danger of death due to electric shock

There are risks of electric shock if modifications are performed by unlicensed personnel.



Prior to operation, disconnect the conveyor system from the power supply and ensure that it is secured against accidental and unauthorised restart!



Electrical installations must only be undertaken by a qualified electrician or under the direct supervision of one!



Non-compliance (e.g. freely accessible contacts, incorrect placement of the ground conductor, etc.) can lead to electric shock and, as a result, to serious injury or death!

Depending on the motor installed on the conveyor belt, the information for the correct electrical connection can be found in the wiring diagram A or B (see chapter "Wiring Diagram" page 47). Use the following assignment:

- Motor Manufacturer "Panasonic": Diagram A
- Motor Manufacturer "Oriental": Diagram B



Note

Regulator and capacitor must be installed in a specially authorised enclosure (e.g. DIN EN 60204-1/IEC 60204-1/VDE 0113-1 valid version, as amended). An appropriate protection (e.g. circuit breaker) must be provided.

Attention

Due to the wide range of configuration options, no general statement about the rotational direction in relation to the connection type can be made, since the rotational direction depends on the respective transmission design (and, therefore, also on the delivered gear ratio).

The direction of rotation changes depends on the gear ratio, therefore, the conveying direction is determined by the connections.

Please note that the conveyor cannot be operated in the reverse direction! Operation is only permitted in the specified direction!

Example:

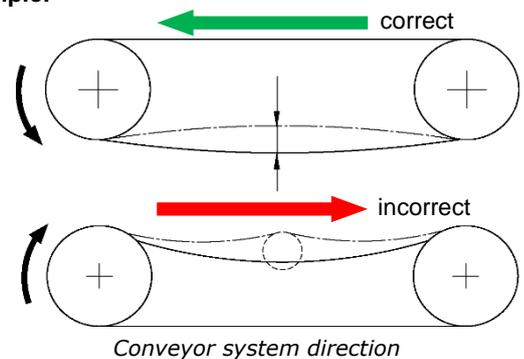

CAUTION



Destruction of the motor

If the conveyor system is operated during commissioning for an extended period of time against the authorised direction, the system can be destroyed.

Run the conveyors in the opposite direction as seldom as possible!

After the electrical connection, briefly switch on the conveyor system (up to several seconds) to check whether the rotational direction is the one required. If this is not the case, change the terminal configuration as shown in the wiring diagram!

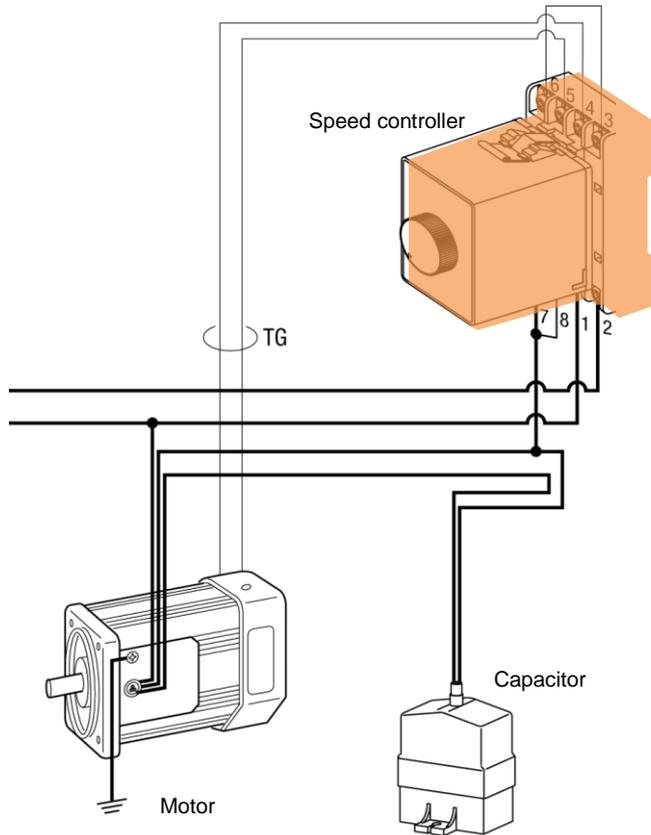

Connection example - motor type with controller

WARNING

 **Risk of stumbling due to incorrect cable layout**

 There is a risk of injury when people stumble over incorrect or inappropriately laid cables.

Wear protective equipment!

Lay cables in cable ducts or channels!

Close off the installation area!

5.5 Wiring Diagram

5.5.1 Motor Manufacturer A (Panasonic Motor)

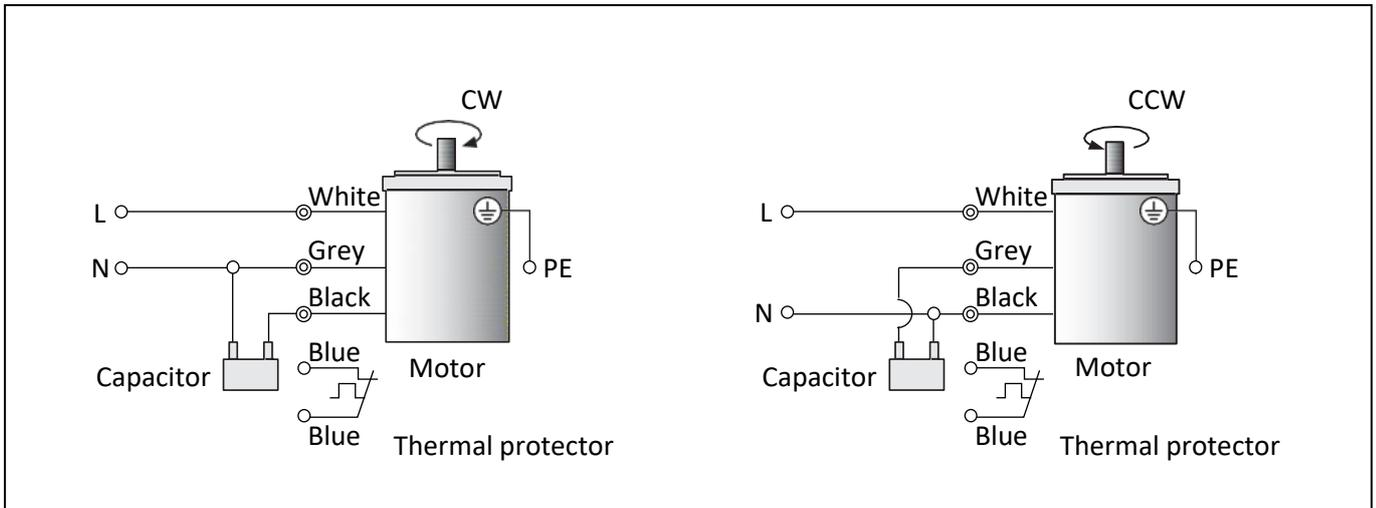

Connection diagram: Induction Motor 6W-25W-40W-60W-90W – 230V/50Hz – 1-phase
 All motors come with thermal protector except for 6W motor.

5.5.2 Motor Manufacturer B (Oriental Motor)

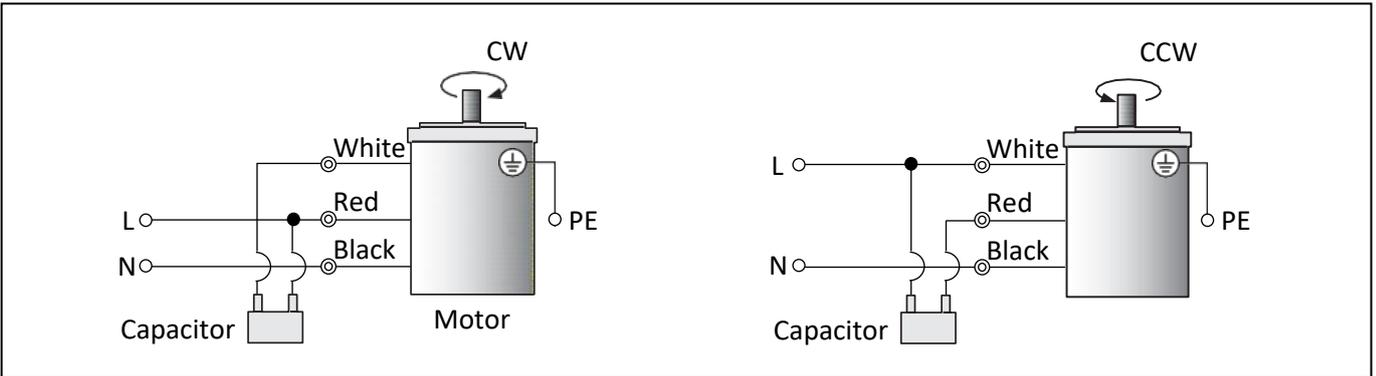

Connection diagram: Induction Motor 6W-25W-40W-60W-90W – 230V/50Hz – 1-phase

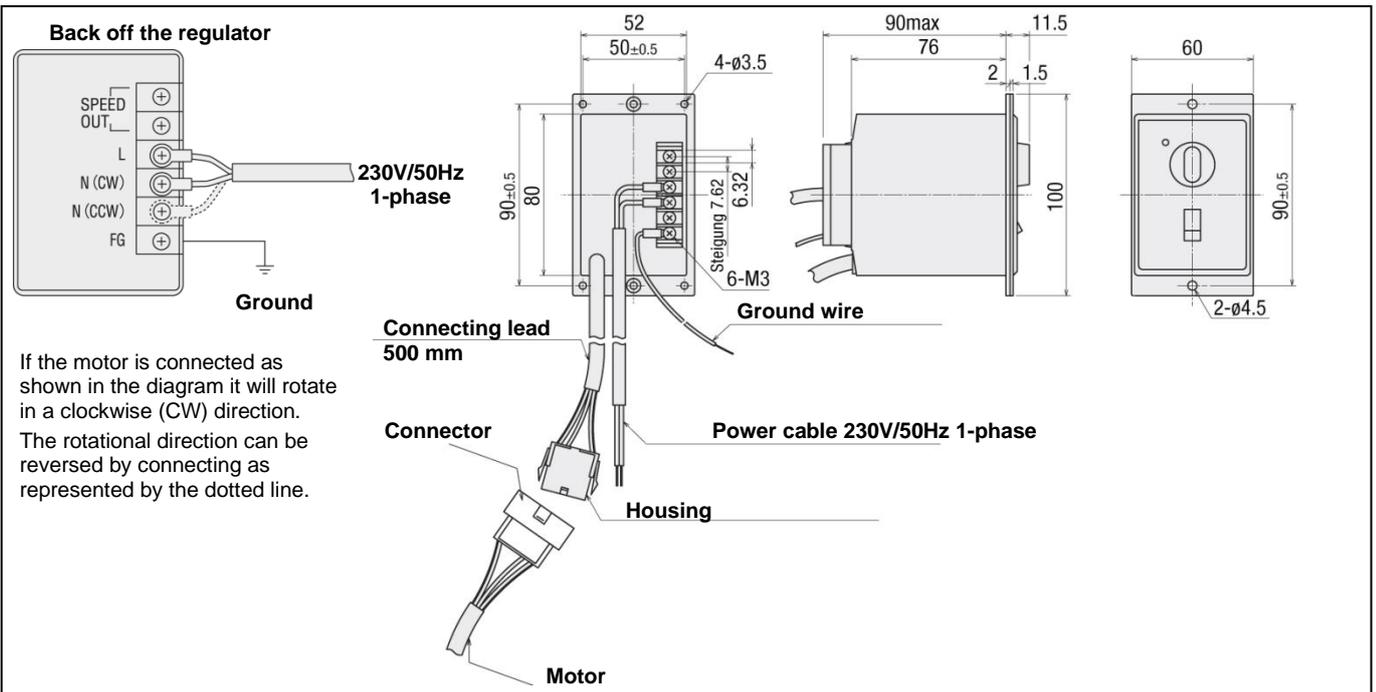

Connection diagram: Variable Speed Motor 6W-25W-40W – 230V/50Hz – 1-phase

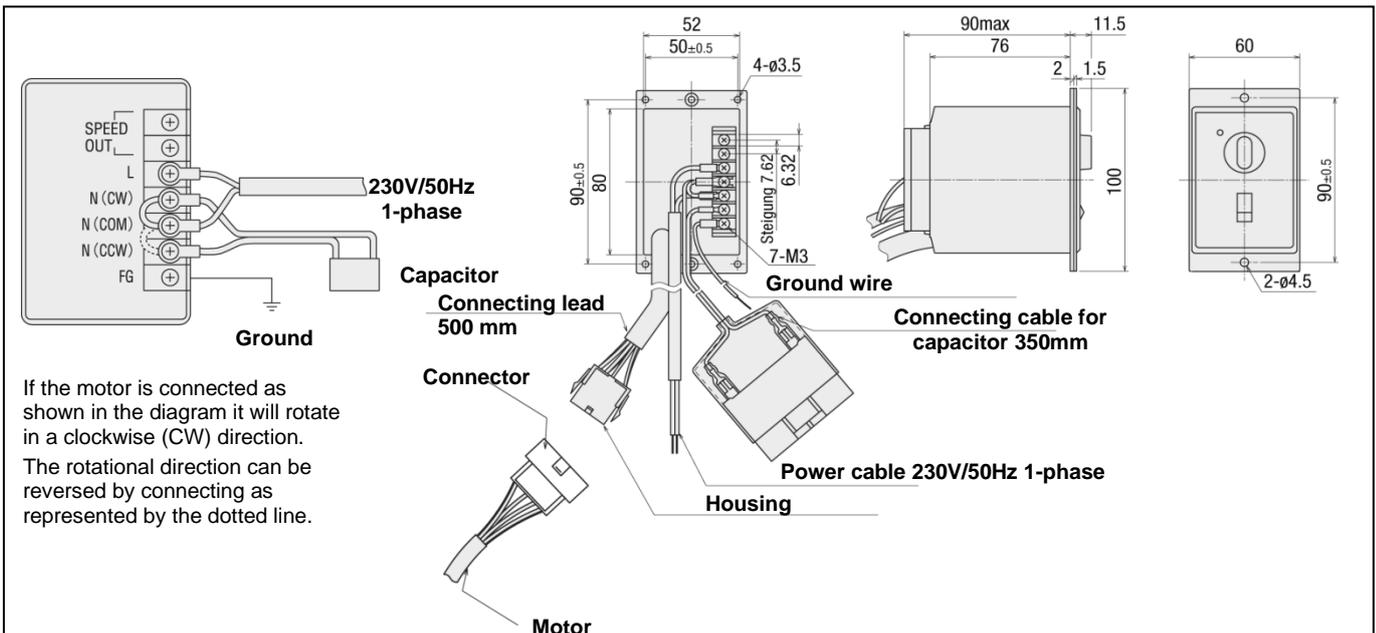

Connection diagram: Variable Speed Motor 60W-90W – 230V/50Hz – 1-phase

5.6 Connection of Third-Party Drives



Important

The drive motors provided by the User (third-party drives) must meet the technical specifications given in Chapter 4.5.1, from page 41 on.

For safe and proper connection of a third-party drive, the following basic properties and dimensions are essential.

Drive torque	▶ Chapter 5.6.1, from page 49 on
Conveying speed	▶ Chapter 5.6.2, from page 49 on
Belt formula list	▶ Chapter 4.4.2.1, from page 39 on
Dimensions	▶ Chapter 5.6.3, from page 49 on

5.6.1 Maximum Permissible Torque

The following values relate to the maximum permissible torque at the motor or gear drive wheel.

Drive power	Torque max.
3.5 W	0.294 Nm
6 W	2.45 Nm
15 W	4.9 Nm
25 W	7.84 Nm
40 W	9.8 Nm
60 W	19.6 Nm
90 W	19.6 Nm

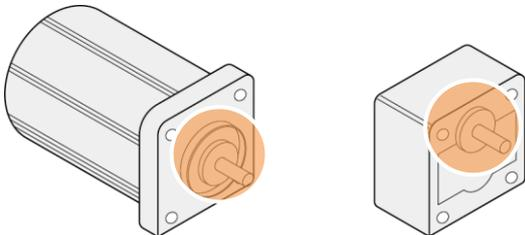

Motor drive wheel (left), Gear drive wheel (right)

5.6.2 Maximum permissible conveying speed

Type	V _{max}	Type	V _{max}
SVKAE	67.7 m/min	CVGCE	56.5 m/min
SVKBE	67.7 m/min	CVGNE	56.5 m/min
SVKNE	56.5 m/min	CVGRE	56.5 m/min
SVKRE	56.5 m/min	CVGBE	67.7 m/min
GVHAE	67.7 m/min	CVGDE	56.5 m/min
GVFAE	67.7 m/min	CVGPE	56.5 m/min
GVHNE	56.5 m/min	CVGWE	56.5 m/min
GVFNE	56.5 m/min	CVSEE	67.7 m/min
GVTSAE	36.0 m/min	CVSFE	67.7 m/min
GVTSE	36.0 m/min	CVSXE	56.5 m/min
GVTWAE	36.0 m/min	CVSFDE	56.5 m/min
GVTWASE	36.0 m/min	CVSTCE	14.4 m/min
GVTWNUE	36.0 m/min	CVSTRE	14.4 m/min
GVTWNSE	36.0 m/min	CVSJAE	56.5 m/min
CVGAE	67.7 m/min	CVSMAE	26.4 m/min

CVLP AE	56.5 m/min	CVDS AE	37.7 m/min
CVMAE	67.7 m/min	CVDSBE	37.7 m/min
CVMBE	67.7 m/min	CVSPCE	64.4 m/min
CVSSAE	22.6 m/min		
CVSPA E	64.4 m/min		
CVGTAE	72.0 m/min		
CVGTBE	64.8 m/min		
CVGTNE	57.6 m/min		
CVGTPE	57.6 m/min		
CVSYE	56.5 m/min		
CVSFAE	27.1 m/min		
CVSFBE	22.6 m/min		
CVSFCE	67.7 m/min		

5.6.3 Drive Motor Dimensions

Drive motor	Application
■ Induction motor	■ for continuous operation (constant conveying speed) in one conveying direction
■ Control motor	■ for variable speed operation (variable conveying speed) with potentiometer for rpm adjustment

The following illustrations and dimensions apply for induction and variable speed motors.

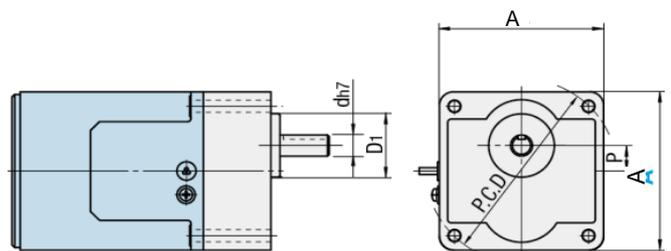
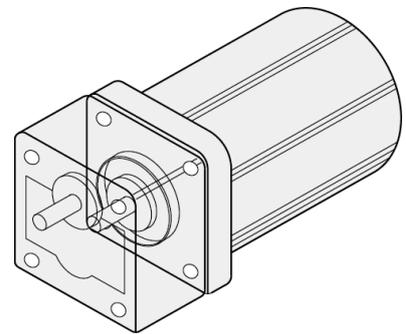

Drive motor dimensions

A	Rectangular dimension
PCD	Pitch circle diameter
D1	Flange diameter
d	Drive shaft diameter
P	Shaft offset

(W)	A	d	Shaft tolerance	D ₁	L ₁	L ₂	L ₃	ℓ	T	(D ₂)	P	a	PCD Ø	Feather key	Feather key tolerance
3.5	22	Ø 6	h7	12	14	29.5 (34.5)	28	2.1	-	22	0	3.5	18	Shaft with flat	
6	60	Ø 8	h7	25	32	26 (33)	75	6	7	65	10	4.5	70	Shaft with flat	
15	70	Ø 10	h7	30		30 (36)	80	5		74	15	5.5	82	4	+0.01 / +0.06
25	80		h7			30	85	6		86				4	+0.01 / +0.06
40	90	Ø 12	h7	36		37	105	5		95	7.5	18	6.5	104	4
60		Ø 15	h7	34	60	120 [150]	7	-	5	+0.00 / +0.05					
90			h7			135 [172]		-	5	+0.00 / +0.05					

Values in () are dimensions for gear heads with a reduction ratio ≥ 30

Values in [] are dimensions for control motors

5.6.3.1 Shaft Form/Drive Wheel Form

Drive wheels have keyways (except 3.5 and 6 W drive motors). The dimensions of the feather keys and the keyways are shown below.

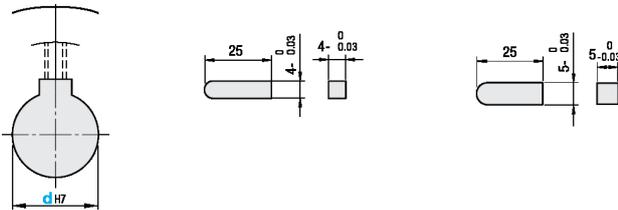

5.6.3.2 Sketch for Induction Motors

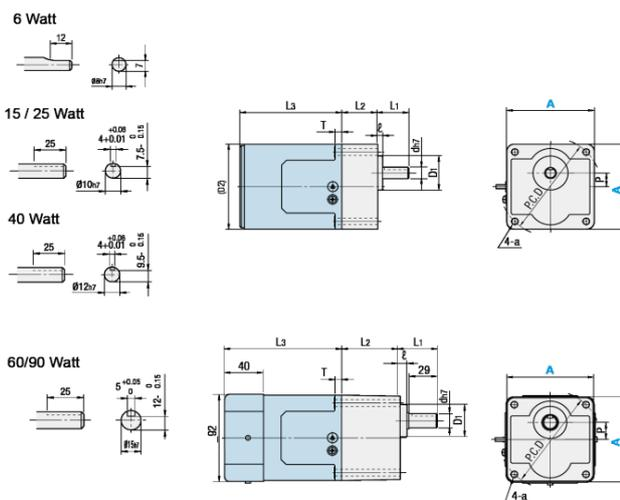

5.6.3.3 Sketch for Control Motors

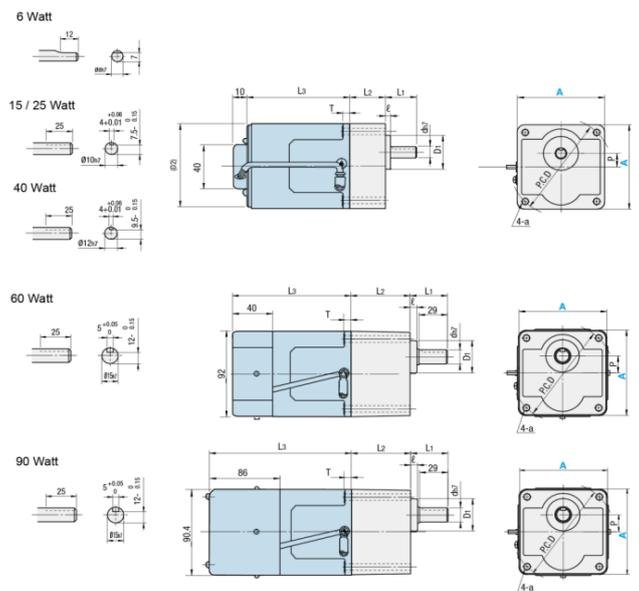

5.6.4 Drive Motor Adapter Plates

To determine the adapter plate needed for a drive motor, the conveyor type, the motor position and the motor power must be known. These data are given in the following overview table.



Note

The appropriate adapter plate sketch can be obtained from MISUMI Europa GmbH according to the reference table!

Type	Motor position	Power
SVKAE/ SVKBE	Standard/ MK	6 W
SVKAE/ SVKBE	Standard/ MK	25 W
SVKNE/ SVKRE	Standard/ MP	6 W
SVKNE/ SVKRE	Standard/ MP	25 W
SVKNE/ SVKRE	Standard/ MP	40 W
SVKNE/ SVKRE	Standard/ MP	90 W
GVHAE/ GVFAE	Standard/ MK	6 W
GVHAE/ GVFAE	Standard/ MK	25 W
GVHNE/ GVFNE	Standard/ MP	25 W
GVHNE/ GVFNE	Standard/ MP	40 W
GVHNE/ GVFNE	Standard/ MP	60 W
GVHNE/ GVFNE	Standard/ MP	90 W
GVTSAE	Standard/ MK	6 W
GVTSAE	Standard/ MK	25 W
GVTWAUE/ GVTWASE	Standard/ MK	6 W
GVTWAUE/ GVTWASE	Standard/ MK	25 W
GVTWNUE/ GVTWNSE	Standard/ MP	6 W
GVTWNUE/ GVTWNSE	Standard/ MP	25 W
CVGAE	Standard/ MK	6 W
CVGAE	Standard/ MK	25 W
CVLPAE	Standard/ MP	25 W
CVLPAE	Standard/ MP	40 W
CVMAE/ CVMBE	Standard/ MK	25 W
CVMAE/ CVMBE	Standard/ MK	40 W
CVSSAE	Standard/ MK	6 W
CVSSAE	Standard/ MK	25 W
CVSSAE	Standard/ MK	40 W
CVSPAЕ	Standard/ MK	25 W
CVSPAЕ	Standard/ MK	40 W
CVGTAE	Standard/ MK	6 W
CVGTAE	Standard/ MK	25 W
CVGTBE	Standard/ MK	25 W
CVGTBE	Standard/ MK	40 W
CVGTNE	Standard/ MP	6 W
CVGTNE	Standard/ MP	25 W
CVGTPE	Standard/ MP	25 W
CVGTPE	Standard/ MP	40 W
CVSYE	Standard/ MP	60 W
CVSYE	Standard/ MP	90 W
CVSFAE	Standard/ MK	6 W

Type	Motor position	Power
CVSFAE	Standard/ MK	25 W
CVSFBE	Standard/ MK	6 W
CVSFBE	Standard/ MK	25 W
CVSFBE	Standard/ MK	40 W
CVSFCE	Standard/ MK	6 W
CVSFCE	Standard/ MK	25 W
CVGCE	Standard/ MK	6 W
CVGCE	Standard/ MK	25 W
CVGNE	Standard/ MK	40 W
CVGNE	Standard/ MP	6 W
CVGNE	Standard/ MP	25 W
CVGRE	Standard/ MP	6 W
CVGRE	Standard/ MP	25 W
CVGRE	Standard/ MP	40 W
CVGBE	Standard/ MK	6 W
CVGBE	Standard/ MK	25 W
CVGDE	Standard/ MK	6 W
CVGDE	Standard/ MK	25 W
CVGDE	Standard/ MK	40 W
CVGPE	Standard/ MP	6 W
CVGPE	Standard/ MP	25 W
CVGWE	Standard/ MP	6 W
CVGWE	Standard/ MP	25 W
CVGWE	Standard/ MP	40 W
CVSEE/ CVSFE	Standard/ MK	60 W
CVSEE/ CVSFE	Standard/ MK	90 W
CVSXE	Standard/ MP	60 W
CVSXE	Standard/ MP	90 W
CVSFDE	Standard/ MK	6 W
CVSFDE	Standard/ MK	25 W
CVSFDE	Standard/ MK	40 W
CVSTCE	Standard/ MK	6 W
CVSTRE	Standard/ MP	6 W
CVSJAE	Standard/ MP	6 W
CVSJAE	Standard/ MP	25 W
CVSMAE	Standard	6 W
CVDSAE	Standard/ MK	40 W
CVDSBE	Standard/ MK	40 W
CVSPCE	Standard/ MK	6 W
CVSPCE	Standard/ MK	25 W

6. Operation



Safety Instructions

Follow safety instructions in Chapter 3, "Safety Instructions".

In addition, follow all safety instructions and signs on the conveyor system and in the manufacturer's documentation in the appendix.

WARNING



Risk due to unauthorised use

There are risks if unauthorised persons have access to the machinery during connection and start-up.

After work is completed, secure the machine against unauthorised restart.

Starting the machine is only allowed after receiving instruction or training.

Before the start of the shift, the instructed and trained personnel must check that the protective and safety equipment is in proper working order. If deficiencies are discovered, the machine must be shut down until these deficiencies are resolved.



Important

Pay attention to the danger zones of the machine.

Do not perform any cleaning in the work areas of the machinery during operation.

Pay attention to the conveyor capacity Do not overload!

6.1 Commissioning

Attention

Specify the responsibilities of the commissioning personnel.

Exchange defective machine parts immediately. For clear identification of the parts, consult the additional documentation in the appendix to these operating instructions.

Do not remove, bypass or work without the safety devices.

Check installation conditions when commissioning for the first time or after a long standstill.



The commissioning of the machine is prohibited until compliance with all requirements of the Directive 2006/42/EC is confirmed!

6.2 Checking functionality prior to operation

DANGER



Risk of death due to damages or defects

There is a risk of death due to damages and defects on the machine.

Never operate the machine if damages have been pinpointed or identified. Replace defective components!

Check electrical and mechanical components of the machine for damage.

Systematically maintain the machine according to the maintenance intervals. The operating company must ensure that maintenance is properly performed according to the manual.

- Prior to commissioning of the conveyor system, assess the proper condition of the machine with a functional test.
- Check that all protective guards of the conveyor system are present, and check their integrity.

6.3 Switching on the conveyor system

The procedure for switching on the conveyor system, either with the motor circuit breaker or with the speed controller, depends on the configuration,.

If the conveyor is connected to a larger control or operating system, the procedure of the entire machine/plant may be used to switch on the machine. A separate on/off switch for the conveyor system is not needed.



On/Off switch

DANGER



Danger due to incorrect operation

There is danger to life and of damage to the machine when it is operated by inexperienced, unqualified or untrained personnel.

Operation only by trained personnel! Competencies must be assigned by the operating company.

The machinery must be switched off during maintenance, set-up and cleaning.

7. Shut-down



Safety Instructions

Follow safety instructions in Chapter 3, "Safety Instructions".

In addition, follow all safety instructions and signs on the conveyor system and in the manufacturer's documentation in the appendix.

7.1 Switching off the conveyor system



Important

If the conveyor system is integrated into a larger control or operating system, it does not have to be separately switched off at the end of each shift.

Shut down at the end of a shift

1. Switch off at the main switch.
2. Secure the machine against unauthorised restart at the end of the shift.

Switching off for a long period

1. Run the conveyor system until it is empty. Make sure that no materials are still on the conveyor.
2. Switch off at the main switch.
3. Physically disconnect the conveyor system from the power supply.

7.2 Bringing the machine to a standstill

The conveyor system must be properly taken out of service for extended downtime, during a relocation, as well as for the permanent withdrawal from service.

DANGER



Danger during disconnection from the power supply by unauthorised personnel

There are always dangers when the conveyor system is disconnected from the power supply by inexperienced or non-qualified personnel.

Only allow authorised personnel to disconnect the power supply!

Shut-down

7

1. Run the conveyor system until it is empty. Make sure that no materials are still on the conveyor.
2. Switch off the conveyor system.
3. Disconnect all power supplies of the conveyor system.
4. Lightly oil any bare metal parts of the conveyor system with oil before storing.
5. Cover the conveyor system to protect it from dirt, dust and other substances during storage.
6. Store the conveyor system on pallets.

WARNING



Unqualified staff can cause risk of injury and pollution



Bringing the conveyor system to a standstill can be dangerous if the staff does not have the appropriate qualifications and skills.

Standstill must be performed by authorised personnel!

Only allow qualified personnel to dispose of equipment and machinery.

Follow local disposal regulations.

7.3 Relocation of the machine

For longer downtimes or long-term standstill, the conveyor system must be properly relocated or disposed of.

For intermediate storage of the conveyor system, the storage area must be cool and dry to prevent corrosion of the parts of the machine. The delivery packaging is designed for a storage period of up to 3 months.

Property	Recommendation
Storage location	dry, enclosed space
Temperatures	-20°C to +60°C
Relative humidity	maximum 85% (no condensation!) Desiccant in the control cabinet/box

WARNING



Risk of injury from tipping / falling

Improper handling or failure to take account of the centre of gravity causes a risk that the conveyor system can tilt or overturn.

Secure the machine against unintentional tilting and instability.

Pay attention to the centre of gravity!

7.4 Disposal of the machine

- Dispose of packing material in accordance with the local regulations.
- Dispose of paperboard packaging, protective packaging made of plastics and preserving agents separately and professionally.
- The machine should be disposed of by an accredited company due to the risk of potential environmental pollution.

The machine (including machine parts, equipment) must be disposed of according to the local disposal regulations and the procedures provided by the local environmental laws of the operating company's country.

If the machine has reached the end of its service life cycle, a safe and proper disposal, specifically of the parts or substances hazardous to the environment, must be guaranteed during dismantling. These include lubricants, plastics, and batteries.

8. Set-up and Accessories



Safety Instructions

Follow safety instructions in Chapter 3, "Safety Instructions".

In addition, follow all safety instructions and signs on the conveyor system and in the manufacturer's documentation in the appendix.

DANGER



Risk of crushing and death due to intervention by unauthorised individuals



There are risks when unauthorised personnel perform modifications.

Disconnect the machine from the power supply and secure against accidental and unauthorised restart before beginning modifications.

Ensure that only authorised personnel make modifications.

Wear protective equipment!

8.1 Drive change

In the event of a failure or defect, the motor of the conveyor system must be changed. The procedures differ depending on the manufacturer of the motor.



Manufacturer's documentation for motors

Follow the instructions for assembly and disassembly of the motor in the manufacturer's documentation. These are located in this manual.

DANGER



Danger of death due to electric shock

There are risks of electric shock if modifications are performed by unlicensed personnel.



Prior to operation, disconnect the conveyor system from the power supply and ensure that it is secured against accidental and unauthorised restart!



Ensure that only authorised personnel make modifications.



8.2 Belt change

The conveyor belt must be replaced when the wear limit is reached, or when there are changes in the demands on the transport belt due to changes in the conveyed materials.

The belt change procedure described below applies to flat belts, timing belts and stainless steel belt conveyors.

WARNING



Risk of injury when belts are missing

There is a risk of injury if the conveyor belt is not installed as moving components of the conveyor system are accessible when the system is switched on.

When changing the belt or when a belt is not installed, the conveyor system must be safety disconnected from the power supply!

Never switch on the conveyor system without a belt, as the belt also acts as an isolating safety guard!

CAUTION



Overloading due to high belt tension

There is a danger of overload and damage the motor and belt if the tension is too high.

Adjust the belt tension so that the drive roller can rotate when the belt is blocked.



Important

If the conveyor system is purchased from MISUMI without conveyor belt, its operation is only permitted when a genuine MISUMI conveyor belt has been installed!

Alternatively, conveyor belts that have the same technical characteristics as the original MISUMI conveyor belts may be used! Heed the technical features specified in Chapter 4.4.1, from page 35 on!

Otherwise the EU Declaration of Conformity will become invalid. MISUMI Europa GmbH accepts no liability whatsoever for any damage or consequential damage caused by the use of a conveyor belt not supplied by MISUMI Europa GmbH!

Make sure that the new belt that is to be installed is suitable for the conveyor and for the material that is to be conveyed!

Use conveyor belts from MISUMI Europa GmbH!

8.2.1 Belt change - Head drive

Procedure for replacement of the belt of conveyor systems with head drives

1. Turn off the main switch and disconnect the power supply by unplugging the conveyor.
2. Mark the relative position of the screws on the frame to capture the belt tension settings!



3. Loosen the tension adjustment screws on both sides. The belt comes off after loosening the screws.

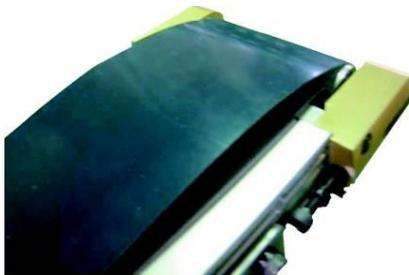

4. Loosen the belt completely and completely unscrew the pulley holder.



5. Remove the belt. When replacing the belt, be careful not to pull out the pulleys.



6. Install the new conveyor belt in the correct direction. Pay attention to directional markings on the back of the belt.
7. Install the belt by following the above-mentioned instructions in reverse order. Install the pulley holder.
8. Finally, adjust the belt tension with the tension adjustment screws.



9. Perform a visual and functional inspection after completing the replacement of the conveyor belt. Pay special attention to loose connectors and loose parts such as tools and screws in the work area of the conveyor.

8.2.2 Belt change - Central drive

Procedure for replacement of the belt of conveyor systems with central drives

1. Turn off the main switch and disconnect the power supply by unplugging the conveyor.
2. Rotate the conveyor 180°.



3. Mark the relative position of the screws on the frame to capture the belt tension settings!

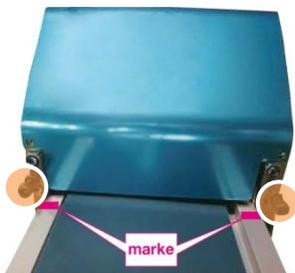

4. Loosen the four voltage adjustment screws. The belt comes off after loosening the screws.

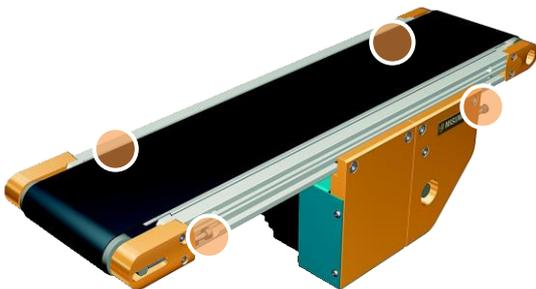

5. Loosen the five screws on the blue cover and remove these.



6. Place the conveyor on its side to remove the screws from the yellow cover. Hold the rollers in position with your hand to secure them against falling.

7. Remove the yellow cover.

8. Carefully remove the rollers.



9. Note the belt routing around the pulleys for subsequent replacement of the belt.

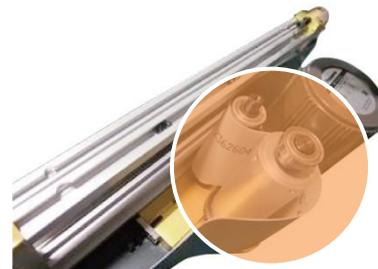

10. Loosen the belt completely and remove it.

11. Install the new conveyor belt in the correct direction. Pay attention to directional markings on the back of the belt.

12. Insert the removed rollers and attach the yellow cover



13. Finally, adjust the belt tension with the tension adjustment screws. Make sure that the belt is not slipping to the side.

8.2.3 Belt Change - Integrated Drive

Procedure for replacement of the belt of conveyor systems with integrated drives

1. Turn off the main switch and disconnect the power supply by unplugging the conveyor.
2. Remove the screws from the front face of the pulley cover and remove it.

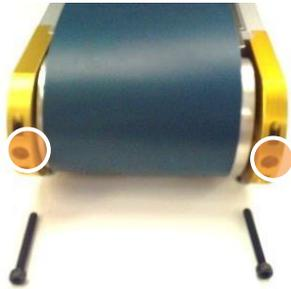

3. Remove the screws of the pulley cover on the conveyor sides and remove it. Please note that you only need to loosen the screws on one side of the conveyor to replace the belt.

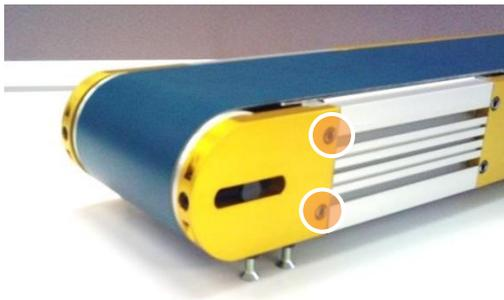

4. Lift the pulley cover off.
5. Remove the belt.

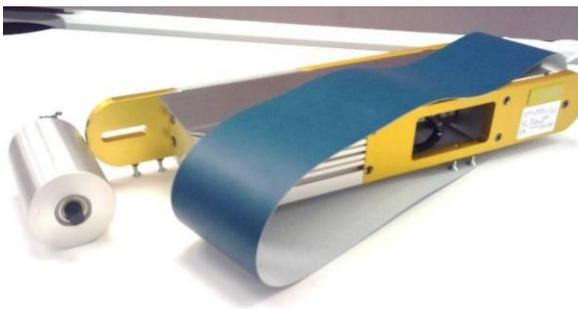

6. Install the new belt and install the cover in reverse order of the disassembly.
7. Finally, adjust the belt tension with the tension adjustment screws.

8.3 Alignment Correction

The conveyors belts can be pre-set by the manufacturer. However, through use or after a belt change, the belt can move off-centre. Straight belt spans must be adjusted or readjusted accordingly.

To correct the alignment, the conveyor must be in operation.

CAUTION



Over-correction of the belt due to one-sided adjustment

There is a risk of damage to the belt edge by overloading of the belt when it is too tightly adjusted on one side.

Perform alignment correction step by step, with constant visual inspection of the belt.

8.3.1 Alignment Correction Direct Drive Conveyors

1. For the alignment correction, set the conveyor onto a flat, stable surface! If necessary, secure the conveyor by fixing it to the floor.
2. Adjust the conveyor horizontally using a level.
3. Loosen the nut of the tension adjustment screw on the side of the slippage of the conveyor in order to slowly tighten the screw. Keep in mind that you need to loosen the screw again if it is too tight and the belt moves in the opposite direction.
4. Observe the belt routing. Repeat the process if there is still slippage.
5. Tighten the nut.
6. Operate the conveyor for some time to stabilise the belt routing.

8.3.2 Alignment Correction Centre Drive Conveyors

1. For the alignment correction, set the conveyor onto a flat, stable surface! If necessary, secure the conveyor by fixing it to the floor.
2. Adjust the conveyor horizontally using a level.
3. Loosen the nut of the tension adjustment screw on the central drive on the side of the slippage in order to slowly tighten the screw. Keep in mind that you need to loosen the screw again if it is too tight and the belt moves in the opposite direction.
4. Observe the belt routing. Repeat the process if there is still slippage.
5. Tighten the nut.

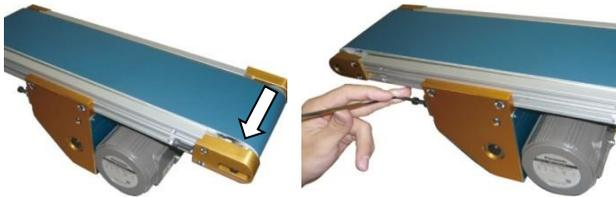

6. Operate the conveyor for some time to stabilise the belt routing.
7. Adjust the tension adjustment screw on the pulley bracket until the previous setting is restored

8.3.3 Alignment correction - Integrated Drive

1. For the alignment correction, set the conveyor onto a flat, stable surface! If necessary, secure the conveyor by fixing it to the floor.
2. Adjust the conveyor horizontally using a level.
3. Loosen the nut of the tension adjustment screw on the front of the conveyor where there is slippage, in order to slowly tighten the screw. Keep in mind that you need to loosen the screw again if it is too tight and the belt moves in the opposite direction.
4. Observe the belt routing. Repeat the process if there is still slippage.
5. Tighten the nut.

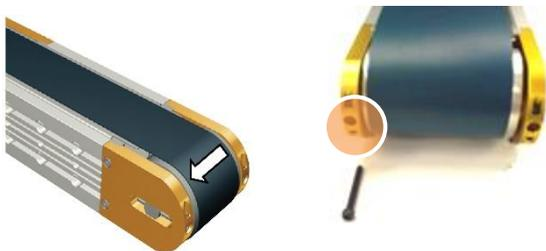

6. Operate the conveyor for some time to stabilise the belt routing.

8.4 Tensioning Belt

The procedure for tensioning the belt varies depending on how the drive unit is installed.

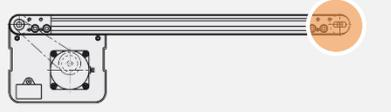
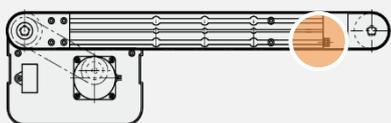
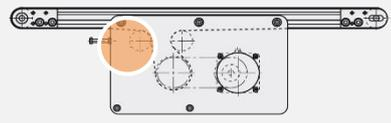
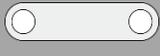
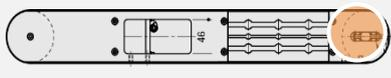
Head Drive 	Belt between the frame profiles: ▶ Tensioning screw at the idler pulley  Belt over the whole width: ▶ Tensioning screw between the idler pulley and the tension pulley 
Centre Drive 	▶ Tensioning screw at the deflection unit 
Integrated Drive 	▶ Tensioning screw at the idler pulley 

8.5 Recommissioning

- Check the ground wire connections for tightness!
- Install all removed nameplates after exchanging cables.
- Always tighten all loosened screw connections after making modifications.
- Check for the presence of all safety and protective devices (protective covers).
- After completion of work, remove all tools, screws, materials and other objects from the work area of the conveyor system.
- Close the control panel and return the keys to the responsible staff.
- After completing maintenance and service, perform a functional test (trial run).

8.6 Accessories

Various accessories are available depending on the environment and use of the conveyor systems.

- Use only accessories from the manufacturer or by its approved suppliers, MISUMI Europe GmbH.
- Information about ordering accessories can be found in Chapter "Order" page 61.



Catalogue

Detailed information on available accessories and spare parts can be found in the catalogue or at www.misumi-europe.com.

8.6.1 Support stand

The conveyor system can be installed on support stands, which can be ordered in different variations (I, H-form) with moveable casters or adjustable screws.



Support stand H-form

8.6.2 Mounting brackets (supports)

Mounting bracket can be used as supporting elements for customised mounting of the conveyor system. Different designs allow for a variety of applications.

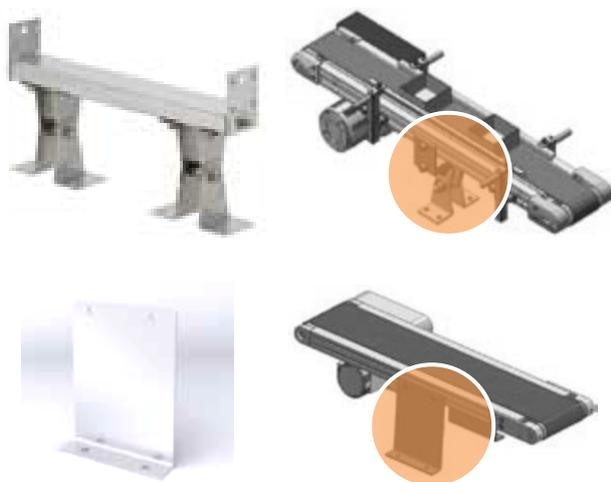

8.6.3 Metal guide rails

To linearly align the conveyed materials on the conveyor system, metal rails in various styles (straight, Z-and Y-shape) can be mounted to the frame of the conveyor.



Z-form

Straight form

Y-shape

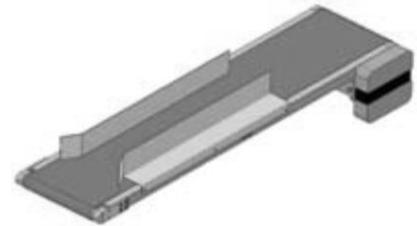

8.6.4 Plastic guide rails

To linearly align the conveyed materials on the conveyor system, rails made of engineered plastics in various styles (straight, Z-and Y-shape) can be mounted to the frame of the conveyor.



8.6.5 Guide rail brackets

For the individual mounting of the plastic or metal guide rails, brackets can be mounted on the conveyor.



Brackets for conveyor belt guide rails made of engineering plastics - Standard

Brackets for conveyor belt guide rails made of engineering plastics - Offset



Holder for conveyor belt guide rails - Standard

Holder for conveyor belt guide rails - Offset



Rod guide rail



Brackets and angle brackets for rod guide rail

8.6.6 Transfer rollers

To support the smooth transfer between linked conveyor systems, transfer rollers are mounted between the conveyors.

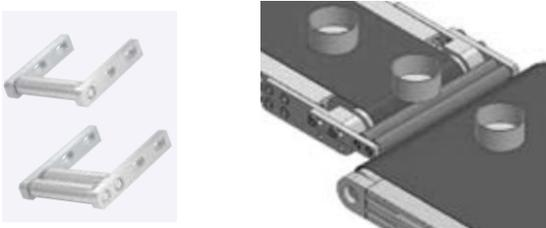

8.6.7 Plastic covers

To cover the transfer route, transparent plastic covers in different shapes can be mounted on the conveyor.



L-shaped plastic covers

U-shaped plastic covers

8.7 Spare parts

When replacing parts that serve as safety devices on the machine, only original parts may be used or equivalent parts, e.g. that have the same safety standard.



Spare parts list

For further information, see the spare parts list in the appendix of this documentation.



Note

The "General Sales and Delivery Conditions" of MISUMI Europa GmbH apply. These are available to the operating company at signing of the contract, at the latest. Your order is confirmed with your signature.

8.8 Order

- When ordering spare parts, use the following contact address:

MISUMI Europa GmbH
Franklinstraße 61–63
60486 Frankfurt am Main
Germany

E-Mail: Mail.tech@misumi-europe.com
Web: www.misumi-europe.com

9. Maintenance



Safety Instructions

Follow safety instructions in Chapter 3, "Safety Instructions".

In addition, follow all safety instructions and signs on the conveyor system and in the manufacturer's documentation in the appendix.

- Observe the national laws on prevention of accidents.
- Carry out prescribed adjustment, maintenance, and repair work according to schedule.
- Adjust the maintenance cycles to the daily requirements.
- Replace defective machine parts as soon as possible.
- Only use tools that are in perfect condition.
- Inform operating personnel prior to commencing maintenance or upkeep work
- Attach information signs to the conveyor system.
- Document all prescribed maintenance work.
- Use only original spare parts which are approved by the manufacturer - especially for safety-relevant components



Technical support

For technical assistance for problems that occur during operation that can not be solved on your own, contact the manufacturer of the conveyor system.

- Before you start any maintenance and repair work on the conveyor follow the safety precautions in the order listed
1. Disconnect the power supply
 2. Secure against restart
 3. Check that the power is off
 4. Ground and bypass
 5. Isolate/cut off adjacent conducting parts
 6. Interrupt protective circuits (conveyors and adjacent machines)

DANGER



Danger of death due to electric shock

There is a danger that residual electrical energy remains in cables and electrical equipment after the power supply is disconnected.



Disconnect the conveyor system from the power, and secure it against accidental or unauthorised restart! Put warning signs on the machine.



Make sure that only authorised personnel performs troubleshooting on electrical equipment!

Contact the manufacturer if you cannot resolve problems.

WARNING



Danger of injury due to residual energy

During maintenance, many dangerous situations can occur.



Wear protective equipment (helmet, shoes, gloves).

Servicing, maintenance and repair should only be performed by skilled or trained staff.

WARNING



Danger of injury when working overhead

There is a risk of falling when working on higher areas of the machine.



Use safe climbing aids and work platforms. Do not use machine components as climbing aids.



Note

The machine operator may also perform maintenance work if he/she has received the proper training or instruction. The interventions the machine operator is permitted to undertake and those that require contacting the appropriate technician must be specified in writing.

The maintenance tasks described below must be performed by qualified personnel.

9.1 Cleaning of the conveyor system

WARNING



Risk of injury from cleansing agents

Failure to comply with the manufacturer's cleaning instructions may cause injuries and health problems when using cleansing agents.



During cleaning, comply with all applicable environmental protection regulations.



When cleaning with volatile substances (e.g. cleansing agents) ensure there is sufficient ventilation.



Never use open flame on or around the machine or around highly flammable solvent cleaners



Always use protective glasses and gloves.

- Clean the engine regularly, and more often when it is exposed to dirt, dust and other substances.
- Only perform cleaning tasks with suitable equipment.
- Wipe off the conveyor system - especially the belt - with a damp cloth to remove dirt, dust and other substances.
- Remove all cleaning aids after performing cleaning work.
- Check that the cleaned areas is functioning.



Important

Ensure that grease and other hazardous substances do not enter the sewer system.



Collect and properly dispose of waste oil and other polluting substances.

9.2 Packing of machine parts

- Pay attention to the following instructions for repacking machine parts if individual machine parts have to be sent to the manufacturer for repair:
- Use cardboard boxes and other packaging material to package machine components in order to avoid damage from external influences during transportation.
- Secure machine components against accidental tipping and instability during transport.

9.3 Maintenance information



Important

For the maintenance tasks described below, preparations must be completed and checked beforehand.

The maintenance intervals depend on the operating conditions and the operational environment. The operating company of the conveyor system must adjust the intervals accordingly, and, if necessary, increase them. If there are any doubts, contact the manufacturer.

Intervals	Description of the maintenance work
daily	Belt routing Perform a visual inspection of the belt routing (immediately after switching on). The belt must run without any obstructions. If the belt is not centred on the drive roller, adjust it accordingly. Visually inspect the wear and tear on the belt.
daily	External damage Perform a visual inspection and functional test for externally visible defects and damage to the components of the conveyor system
daily	Electrical cabling/wiring Check cabling/wiring for stability to be sure that regular movement will not be hindered. Refasten them if necessary.
daily	Stability Check the stability of the conveyor system. If necessary, tighten the fasteners.
daily	Ease of movement of components Check that the moving parts (transfer rollers, rollers) move smoothly. If necessary, lubricate them.
daily	Cleaning Clean dirt, dust and other particles, deposits, and oil from any surfaces of the machine.
daily	Fitted Accessories Check the sensors, light switches and stoppers fit tightly. Refasten them if necessary. Replace defective components.
daily	Cleaning Accessories Clean sensors, light sensors and light barriers. Do not use caustic cleansing agents.
daily	Tight-fitting protective covers Make sure all guards are present and fit tightly.
weekly	Motor wear Check the wear on the motor. Replace defective bearings if necessary. Clean the cooling fins.
monthly	Belt tension Check the belt tension and all screw connectors. Check bearings for noise and damage
quarterly	Electrical cabling/wiring Check the cable ducts of the limit switches, sensors, connectors, junction boxes and cables for breakage, wear, damage, dirt, dust, and other substances. Replace them as needed.
quarterly	Motor Perform a visual check of the motor. Check the temperature and noise level, and check for loss of oil.

twice yearly	Electrical cabling/wiring Perform a visual check of the main power feed and cable connections in the switching cabinet. Replace defective parts if necessary.
yearly	Safety circuit Perform a visual and functional check of the safety circuit. Document these inspections.
yearly	Electrical cabinet / electrical components Clean the switching cabinet housing and the electrical components. Check switching documentation for completeness.
yearly	Signs and warning symbols Check signs and warning symbols. Replace them as needed.
4 years	Electrical devices Perform an expert examination of the conveyor system's electrical equipment at least once every 4 years.

WARNING

Risk of injury from unexpected start

Body parts and clothing can become entangled or be pulled into the machine due to an unexpected start of the machine (e.g., during a restart after a power failure or disruption).

Extra care is necessary when working with unlocked or dismantled safety devices (e.g. during set-up, maintenance, and repair).

9.4 Finishing maintenance work

- Check the ground wire connections for tightness!
- Make sure that all necessary work was carried out according to the maintenance schedule
- After replacing cables, lines and operating materials, re-attach all previously affixed identification signs.
- Always tighten loose screws when performing maintenance and upkeep work.
- Check for the presence of all safety and protective measures.
- After completion of work, remove all tools, screws, materials and other objects from the work area of the conveyor system.
- Close the control panel and return the keys to the responsible staff.
- After completing maintenance and service, perform a functional test (trial run).
- Turn over the conveyor system to the operating personnel.

10. Fault Clearance



Safety Instructions

Follow safety instructions in Chapter 3, "Safety Instructions".

In addition, follow all safety instructions and signs on the conveyor system and in the manufacturer's documentation in the appendix.

WARNING



Injury due to human misconduct or lack of qualifications

There are dangers due to human misconduct when an error occurs.

Analysing and troubleshooting must be performed by qualified personnel that are trained and familiar with the machinery.

In the case of recurring faults, immediately notify qualified staff.

DANGER



Danger of death due to electric shock



There is a danger that residual electrical energy remains in cables and electrical equipment after the power supply is disconnected.



Disconnect the conveyor system from the power, and secure it against accidental or unauthorised restart! Put warning signs on the machine.



Make sure that only authorised personnel performs troubleshooting on electrical equipment!



Contact the manufacturer if you cannot resolve problems.

Malfunctions can occur. These are listed in chapter "Frequently Asked Questions (FAQ)" page 66 with the respective troubleshooting information.



Technical support

For technical assistance for problems that occur during operation that can not be solved on your own, contact the manufacturer of the conveyor system.

10.1 Procedure in Case of Operational Malfunctions

Troubleshooting a conveyor system:

1. Disconnect the conveyor system from the power supply (turn off at the main switch)
2. Secure conveyor system
3. Attach warning signs to the conveyor system
4. Troubleshooting by qualified personnel
5. Restart with test run
6. Turn over to operating personnel

WARNING



Risk of injury during a restart after fault clearance

The position of movable components is unknown. The sudden start-up of the machine components and the release of stored energy are dangerous.

Check the safety devices! Only begin operating the conveyor system after the fault is corrected and a functional test has been performed

10.2 Troubleshooting

- Before starting work on electrical equipment, carry out the following safety precautions in the order given.

1. Disconnect the power supply
2. Secure against restart
3. Check that the power is off
4. Ground and bypass
5. Isolate/cut off adjacent conducting parts
6. Interrupt protective circuits (conveyors and adjacent machines)
7. Remedy fault

10.3 Frequently Asked Questions (FAQ)

Belt running incorrectly

Please check the possible reasons as described below.

1. Check conveyor system for bending or twisting of the aluminium frame or the housing.
2. Check belt tension (possibly loose belt).
3. Check pulleys, and tensioning and guidance rollers for foreign matter.

Initially the belt may run off-centre, but will correct itself after it has been in operation a short time.

Belt moves to one side

Please check the possible reasons as described below.

1. May occur due to a bent or twisted aluminium profile or housing.
2. The belt may slip to one side when the load is distributed unevenly.

Belt moving slower

Please check the possible reasons as described below.

1. Check for any dust or dirt in the drive area (pulley, tension or guidance roller).
2. The belt may be worn. Replace the belt.

Vibrations and noise occur

Please check the possible reasons as described below.

1. The timing belt may be too loose or too tight.
2. The belt may be worn. If the reverse side is worn, replace the belt.
3. The belt may have been damaged or there may be foreign matter on the pulley or the tensioner and guidance rollers.

The conveyor does not work

Please check the possible reasons as described below.

1. Check if the power is turned on (power supply, panel).
2. There may be an overload. Make sure that the load does not exceed the capacity.

EC Conformity Declaration

We, the manufacturer

MISUMI Corporation
First Bldg., 5-1 Koraku 2-chome, Bunkyo-ku
Tokyo 112-8583, Japan

and our Authorised Representative in Europe

Mr. Koichi Tsunematsu
Managing Director

MISUMI Europe GmbH
Franklinstraße 61–63
60486 Frankfurt am Main
Germany

declare, having sole responsibility, that the products

SVKAE, SVKBE, SVKNE, SVKRE, CVGAE, CVGCE, CVGNE, CVGRE, CVGBE, CVGDE, CVGPE, CVGWE, CVSEE, CVSFE, CVSXE, CVSXE, CVSYE, CVSFAE, CVSFBE, CVSFCE, CVSFDE, CVSJAE, CVSMAE, CVLPAE, CVMAE, CVMBE, CVSTCE, CVSTRE, CVGTAE, CVGTBE, CVGTNE, CVGTPE, CVSPA, CVSSAE, CVDSAE, CVDSBE, CVSPCE, CVSAE, CVSBE, CVSNE, CVSPE, CVSCE, CVSDE, CVSRE, CVSWE, CVSTAE, CVSTBE, CVSTNE, CVSTPE, GVHAE, GVFAE, GVHNE, GVFNE, GVTSAE, GVTSNE, GVTWAE, GVTWASE, GVTWNUE, GVTWNSE

to which this declaration relates, conform to the following standards and guidelines

- **EN620:2002 +A1:2010**
- **Machinery Directive 2006/42/EC (including Low Voltage Directive 2014/35/EU)**
- **EMC Directive 2014/30/EU**

The relevant products are manufactured and tested according to the corresponding quality controls.

Authorized representative for the compilation of the technical documentation:

NAKAJIMA NOBUHIRO



February 2022

NAKAJIMA NOBUHIRO
General Manager
Head of Marketing, IM G
IM Corporate entity

EU Declaration of Incorporation

We, the manufacturer

MISUMI Corporation
Iidabashi First Bldg., 5-1 Koraku 2-chome, Bunkyo-ku
Tokyo 112-8583, Japan

and our Authorised Representative in Europe

Mr. Koichi Tsunematsu
Managing Director
MISUMI Europe GmbH
Franklinstraße 61–63
60486 Frankfurt am Main
Germany

declare, having sole responsibility, that the products (incomplete conveyor systems, i.e. without drive unit)

SVKAE, SVKBE, SVKNE, SVKRE, CVGAE, CVGCE, CVGNE, CVGRE, CVGBE, CVGDE, CVGPE, CVGWE, CVSEE, CVSFE, CVSXE, CVSYE, CVSF AE, CVSFBE, CVSFCE, CVSFDE, CVSJAE, CVSM AE, CVLP AE, CVMAE, CVMBE, CVSTCE, CVSTRE, CVGTAE, CVGTBE, CVGTNE, CVGTPE, CVSPA E, CVSSAE, CVDSA E, CVDSBE, CVSPCE, CVSAE, CVSBE, CVSNE, CVSPE, CVSCE, CVSDE, CVSRE, CVSWE, CVSTAE, CVSTBE, CVSTNE, CVSTPE, GVHAE, GVFAE, GVHNE, GVFNE, GVTSAE, GVT SNE, GVTWAUE, GVTWASE, GVTWNUE, GVTWNSE

to which this declaration relates, conform to the following standards and guidelines!

- **EN620:2002 +A1:2010 (except for the drive requirement)**
- **Machinery Directive 2006/42/EC (except for the drive requirement)**

Operation of the product is prohibited until it has been established that the machinery meets all of the essential requirements of the Directive 2006/42/EC.

The relevant products are manufactured and tested according to the corresponding quality controls.

Authorized representative for the compilation of the technical documentation:

NAKAJIMA NOBUHIRO



February 2022

NAKAJIMA NOBUHIRO
General Manager
Head of Marketing, IM G
IM Corporate entity