

HEIGHT ADJUSTMENT UNITS FOR CAMBER CORRECTION

GENERAL PURPOSE SCRAP CUTTERS

RoHS

CAUA (With slotted hole)

CAUN (Without slotted hole)

Material: G040F, 40HRC

S ₁	Catalog No.		1mm increments		A (Selection)	Base unit price 1~9 pieces	
	Type	W	L	S		CAUA	CAUN
S-4	CAUA (With slotted hole)	6	70~120	10~25	1	Quotation	
	CAUN (Without slotted hole)	8			2.5		
		10			5		

Order Catalog No. - L - S - A
 CAUA 6 - 100 - 20 - 5
 CAUN 6 - 102 - 20 - 2.5

Days to Ship Quotation

Price Quotation

- Features**
- These height adjustment units are used to correct the camber (material warpage) of thin workpieces such as connector lead frames.
 - By using the push-pull bolts to move the adjustment unit back and forth, fine adjustments can be made to the correction punch height.

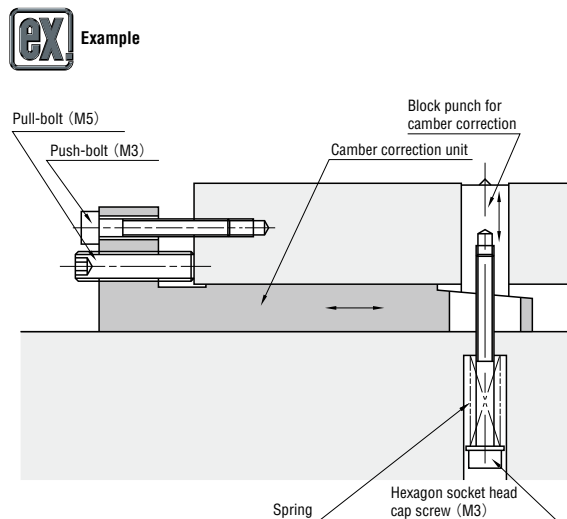

RoHS

SCL

SCT

Material: Equivalent to SKD11, 60~63HRC

A	B	Catalog No.		L	Base unit price 1~9 pieces	
		Type	T		10mm increments	Shortest L~L60
48	-	SCL	10	20~60	Quotation	
54			16			
63			25			
50	32	SCT	20	30~100	Quotation	
			25			
			30			

Order Catalog No. - L
 SCL 16 - 20
 SCT 20 - 50

Days to Ship Quotation

Price Quotation

Alterations Catalog No. - L(LC)
 SCT 25 - LC55

Alteration	Code	Spec.	1 Code
	LC	L dimension change 1mm increments Lmin.<LC<Lmax.	Quotation

