

GUIDE FOR ELECTROFORMING SPRUE BUSHINGS



■ Features of electroforming sprue bushing

- 1. Sufficient mold-releasing ability**

The surface roughness of the inside surface of an electroforming sprue bushing is as fine as that of a steel sprue bushing. As a result, it is possible to separate the cooled and solidified from the mold more smoothly. This is expected to be effective when using resin (e.g. acrylic resin, polycarbonate resin, etc.) that necessitates a high injection pressure to inject it into the mold.
- 2. Reduction of molding cycle time**

An electroforming sprue bushing has good separation performance, so it is possible to reduce the draft angle (A°) of the sprue. By reducing the draft angle, the thickness of the sprue can be minimized, enabling the cooling time during the molding process to be reduced.
- 3. Excellent corrosion resistance**

The raw material of the sprue is nickel alloy. This ensures that the sprue does not corrode when exposed to gas components emitted from the resin or moisture in the air.

■ Method of manufacturing electroforming sprue bushings

1. A core rod (mother die) is manufactured with brass or other metals that can be processed easily.
2. Nickel alloy is deposited over the core rod by means of electro forming until the required thickness is obtained.
3. The external shape is formed by machining. The core rod is extracted, and finish processing is performed.

Electroforming for this product is performed in a multi-stage process that enables the sprue bushing's internal surface to harden more for improved abrasion resistance, while making its external surface soft for better tenacity.

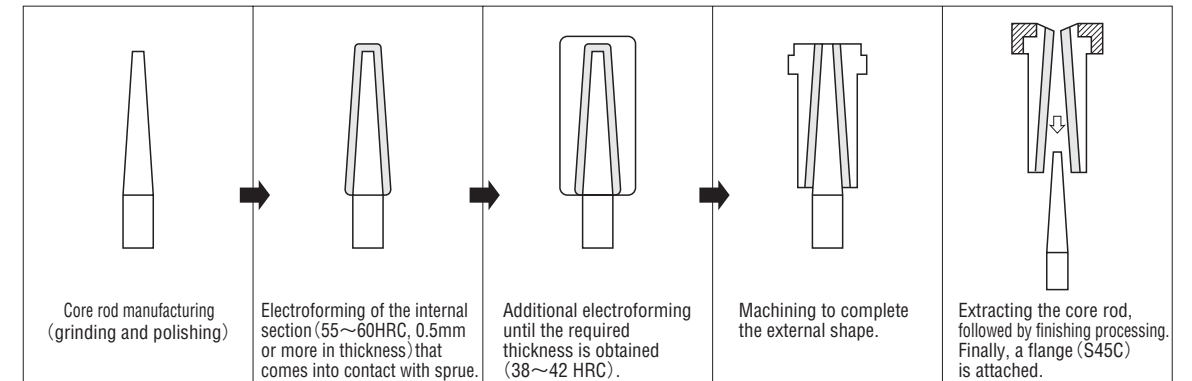

■ Structure

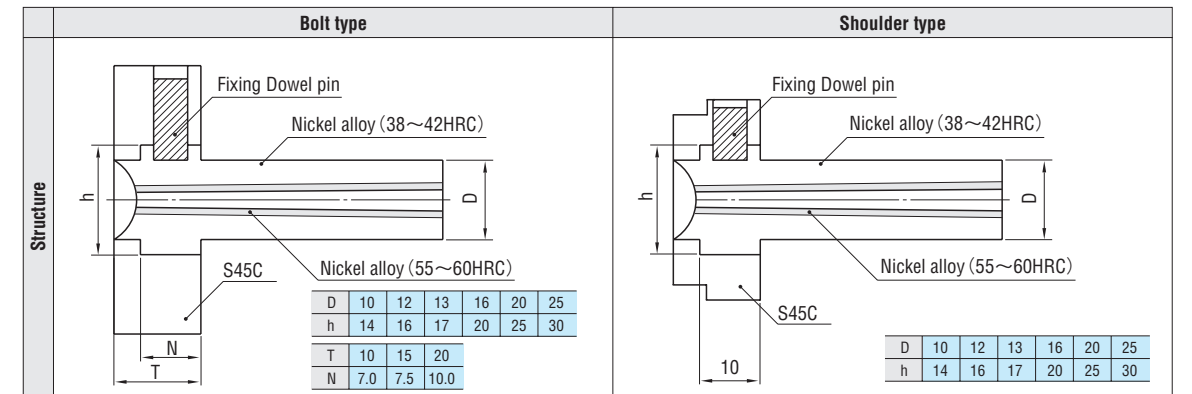

- ⚠ Although this sprue bushing's body and flange are made of different materials, they cannot be separated. Body: Nickel alloy (body's internal section: 55~60 HRC; body's external section: 38~42 HRC) and flange: S45C.
- ⚠ When the size of attachment hole of metal mold is larger than size h, only dowel pin receives the nozzle pressure, which may cause any damage like the flange broken off the bushing. Moreover, please note that a similar trouble occurs when the chamfering of the attachment hole is larger than size h.
- ⚠ Note that the sprue bushing will soften if exposed to heat for a long period. (It can withstand 400°C.)
- ⚠ Use Steel Sprue Bushings instead when glass fiber resin or high hardness resin applied as the electroforming Sprue Bushings are inferior to Steel Sprue Bushings in abrasion resistance.